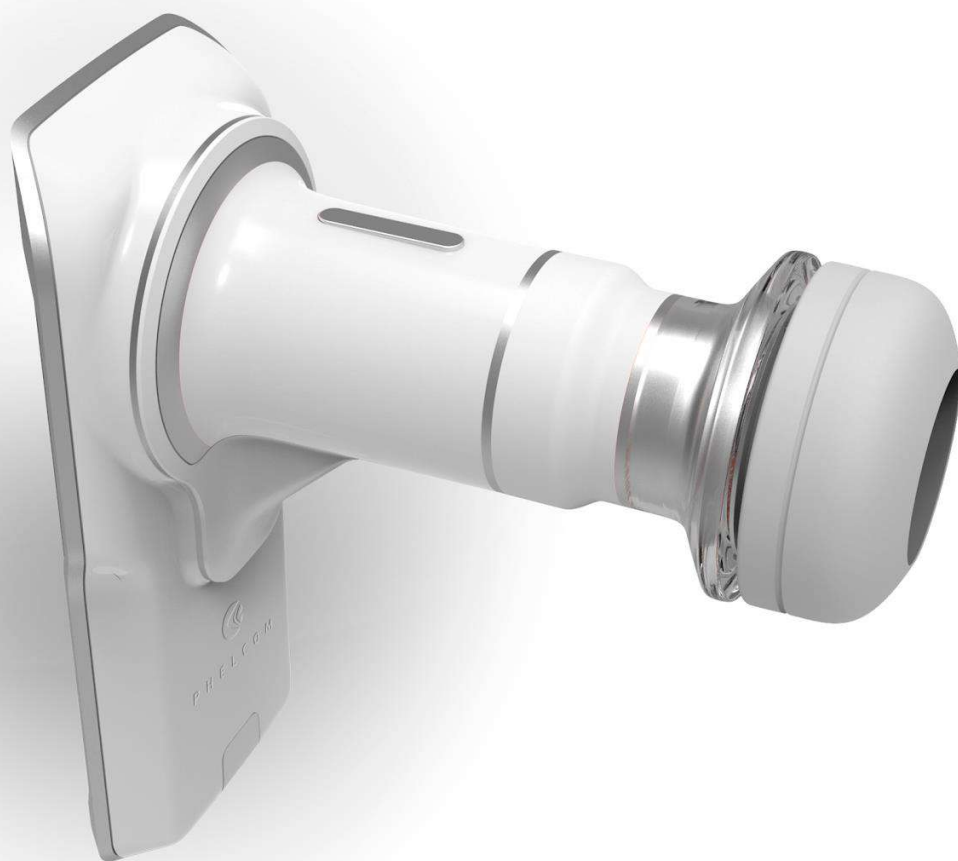
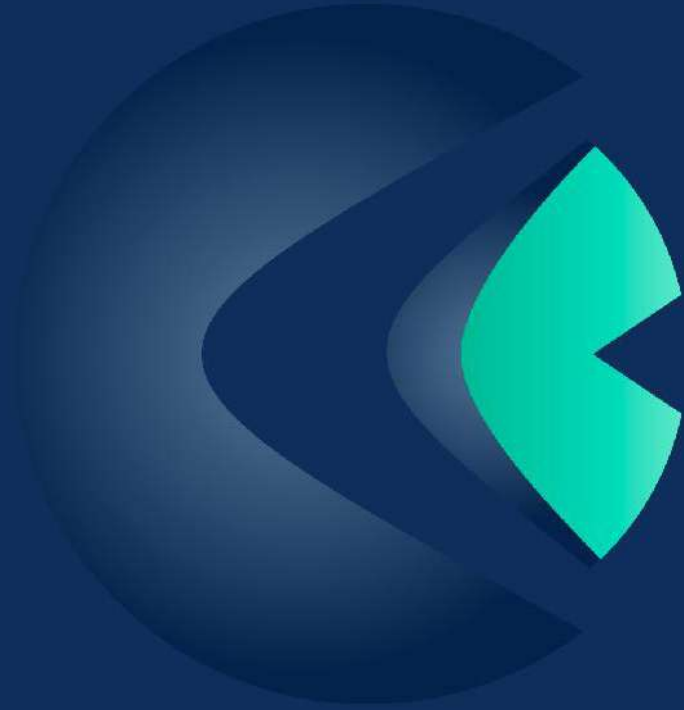


Eyer[®]

USER MANUAL



Rx ONLY



5

CONTENTS

1. Compliance	6
1.1. Safety Guidelines	6
1.2. Indication for use	7
1.3. Intended users	7
1.4. Intended patient population	7
1.5. Clinical benefits	7
1.6. Contraindications and limitations	8
2. Introduction	9
2.1. Usage	9
2.2. Overview	9
2.3. Setup and electrical connections	10
3. Eyer®	13
3.1. Device features	13
3.1.1. Operation	14
3.2. Application	15
3.2.1. Device start screen and access	15
3.2.4.1. Patients	25
3.2.4.1.1. Creating patient profiles through Eyer®	25
3.2.4.1.2. Patient personal information	27
3.2.4.1.2.1. Info	27
3.2.4.1.2.2. Removing a patient profile through Eyer®	28
3.2.4.1.2.3. Exams	29
3.2.4.1.2.4. Creating exams through Eyer®	29
3.2.4.1.2.5. Image capture screen	30
3.2.4.1.2.6. Captured images	34
3.2.4.1.2.6.1. Synchronization failure	42
3.2.4.1.2.7. Image analysis and editing through Eyer®	43
3.2.4.1.2.7.1. Cropping	43
3.2.4.1.2.7.2. Image Measurement	44
3.2.4.1.2.7.3. Image Rotation	44
3.2.4.1.2.7.4. Levels	45
3.2.4.1.2.7.5. ISNT Function	45
3.2.4.1.2.8. Removing images through Eyer®	48
3.2.4.1.2.9. Removing exams through Eyer®	48
3.2.4.1.2.10. Creating and editing diagnosis through Eyer®	49
3.2.4.1.2.11. Sending files by email	52
3.2.4.1.2.12. Device printer setup	53

3.2.4.2. Exams	53
3.2.4.3. Options	54
3.2.4.3.1. Clinic	55
3.2.4.3.2. System	55
3.2.4.3.2.1. Logs	56
3.2.4.3.2.2. Defaults	56
3.2.4.3.2.3. Advanced Resources	57
3.2.4.3.2.4. Language	58
3.2.4.3.2.5. Terms and conditions of use	59
3.2.4.3.3. Device	59
3.2.4.3.3.1. Calibration	60
3.2.4.3.3.2. About	60
3.2.4.3.3.3. User Manual	61
3.2.4.3.4. Servers	61
3.2.4.3.4.1. Common server setup	62
3.2.4.3.4.2. DICOM servers setup	63
3.2.4.3.4.3. FTP server setup	64
3.2.4.3.4.4. SMB/CIFS server setup	65
3.2.4.3.4.5. Local Folder	66
3.2.4.3.4.6. DICOM file information	66
4. Carrying out exams	70
4.1. Posterior segment	70
4.2. Anterior segment	72
5. Maintenance, handling and sanitizing	72
6. Packing, storage, transportation, site selection, operation, and environmental conditions	74
7. Accompanying parts and accessories	75
7.1. Accessories	75
8. Disposal	76
9. Cables and connections	77
9.1. Cables	77
9.2. Connections	77
10. Technical Data	79
10.1. Optical characteristics	79
10.2. Electrical characteristics	80
11. Warning	82
12. Troubleshoot Guide	83
13. Electromagnetic Safety Standards	85
13.1. Supplier declaration and guidelines - Electromagnetic emissions	86
13.2. Supplier declaration and guidelines - Electromagnetic immunity	87

13.3.	Recommended minimum separation distances from mobile RF communication devices to Eyer®	89
13.4.	Radio frequency interference	90
14.	Biocompatibility	92
15.	Glossary and symbols	93
16.	Cybersecurity Information	95
16.1.	Objective	95
16.2.	System overview	95
16.3.	General principles	95
16.4.	Cybersecurity functions	95
16.5.	Data backup	96
17.	Term of Warranty	96


1. Compliance

Phelcom Technologies developed this device according to worldwide quality standards, prioritizing patient and operator safety, electromagnetic compatibility and friendly operational flow, thus making **Eyer®** Retinal Camera safe, reliable and robust, meeting the most varied demands of fundus imaging for diagnosis and screening purposes. Main quality standards adopted follow below:

- ISO 13485:2016
- ISO 14971:2019
- IEC 60601-1:2005+AMD1:2012
- IEC 60601-1-2:2014
- IEC 60601-1-6:2011
- IEC 60601-1-9:2014
- IEC 62366:2010
- IEC 62304:2004
- ISO 10993-1
- ISO 15004-1:2020
- ISO 10940:2009
- ANSI Z80.36-2016

1.1.Safety Guidelines

Eyer® Retinal Camera is a low-risk device that complies all requirements of ISO 15004-2020, ISO 10940:2009 and ANSI Z80.36-2016, being classified as Group 1 fundus camera. It means that there is not any risk for the patients related to lighting during retinal imaging. Even so, we strongly recommend following the guidelines below:

- Follow the information on labels and read this User Manual carefully before turning on and using the device. Wherever the symbol  is found, read all suggested recommendations carefully.
- This device is not suitable for use in the presence of flammable mixtures containing air, oxygen, or nitrous oxide.
- Product must be used as a diagnostic tool for eye diseases, having no treatment function.
- Device operation does not require the operator to wear an individual protection device. However, wearing protection device is optional in adverse conditions.
- Keep the device in a safe location. Avoid shocks and vibrations.
- Do not clean with abrasive solutions. Follow the sanitizing procedure listed in this manual.
- Avoid seeping of any liquid or any particle material inside the device.

- Use no component parts not mentioned in this manual, since their use may damage the device, causing warranty void.
- Avoid exposing the device to sudden changes of temperature and humidity, since it may cause condensation on lenses, which compromises optical performance.
- A fragile part of the system is exposed when the smartphone is disengaged. Be extra careful to avoid damage of optical components, such as scratches, dust, oil, or any other dirt that compromises the device performance.
- User is entirely responsible for using any non-specified part, accessory, or material.
- Avoid falls and shocks, extending the service life of the device. Damages caused by falls or shocks are not covered by warranty.
- Device shall not be used in case any component part is damaged. Contact **Phelcom** technical staff to request repair.
- Never disassemble the device, since it may damage optical and electronic parts, as well as fragile mechanisms.
- Contact **Phelcom** technical support in case there are any problems related to the device.
- Device must be used either in clinical/hospital locations or on-field itinerary campaigns with a trained operator.

1.2. Indication for use

Eyer[®] Retinal Camera is a medical non-mydrriatic digital camera, a Samsung Galaxy S10 smartphone to capture digital images and videos of the fundus of the human eye, surface of the human eye and surrounding areas.

1.3. Intended users

The device may only be operated by persons who have been properly trained, who are familiar with fundus cameras, ophthalmoscopes, etc., or who have the required knowledge to operate the device or a similar device. This device may only be used in accordance with its intended use.

1.4. Intended patient population

All patients may be imaged with **Eyer**[®] Retinal Camera.

1.5. Clinical benefits

Eyer[®] Retinal Camera can be operated **non-mydrriatically**. Whit **Eyer**[®] Retinal Camera **digital images** can be stored for follow-up or consultation purposes. The field of view is 45 degrees allowing a detailed diagnosis. The operation of **Eyer**[®] Retinal Camera can be learned quickly, and even an inexperienced camera operator can capture images with sufficient quality for quick screening purposes.

Eyer[®] Retinal Camera provides versatility for diagnosing different patient groups

that are not able to sit in front of desk-top fundus cameras (e.g., supine patients, wheelchair patients).

Due to small size and portability **Eyer® Retinal Camera** can also be used for homecare visits and remote screening camps.

1.6. Contraindications and limitations

Because prolonged intense light exposure can damage the retina, the use of the device ocular examination should not be unnecessarily prolonged, and the brightness setting should not exceed what is needed to provide clear visualization of the target structures.

The retinal exposure dose for a photochemical hazard is a product of the radiance and the exposure time. If the value of radiance were reduced in half, twice the time would be needed to reach the maximum exposure limit.

While no acute optical radiation hazards have been identified for direct or indirect ophthalmoscope, it is recommended that the intensity of light directed into the patient's eye be limited to the minimum level which is necessary for diagnosis. Infants and persons with aphakia or diseased eyes will be at greater risk. The risk may also be increased if the person being examined has had any exposure with the same instrument or any other ophthalmic instrument using a visible light source during the previous 24 hours. This will apply particularly if the eye has been exposed to retinal photography.

Eyer® Retinal Camera is classified as Group 1 based on standard ANSI Z80.36:2016. The daily usage time and maximum allowed number of pulses is calculated based on optical classification results according to standard ANSI Z80.36:2016.

2. Introduction

By acquiring **Eyer**[®] Retinal Camera you opted for modern, precise, and reliable device to carry out high-quality ophthalmological exams, in accordance with most rigorous safety regulations.

2.1. Usage

Eyer[®] Retinal Camera is a device that provides lighting of the posterior and anterior portions of the human eye. It enables imaging of such structures to diagnose diseases in those regions. There are three available exams: color retinography, red-free retinography and anterior segment imaging.

Eyer[®] advantage, compared to conventional devices, is mobility, usage, quality exams and extremely high connectivity.



Fundus imaging requires equipment operation by trained and skilled personnel. Operator is responsible for learning the techniques applied to this system.

This device is designed for clinical/hospital locations, as well as on-field patient screening. Its use does not imply secondary, side, or adverse effects.

This User Manual contains information on assembling, connections, adjustments, operation, and maintenance, to enable full use of the device. Look forward to reading all the contents and keeping the manual reachable for reference and checking.

In case of any information, doubt, suggestion, or complaint about device components, please contact **Phelcom**. Always count on the technical staff to help and guide you, maximizing device usefulness.

2.2. Overview

Eyer[®] can be used in clinic/hospital locations and on-field. Room temperature must not exceed 40°C (104°F). To assure **Eyer**[®] appropriate functioning, it must be correctly installed according to the conditions below:

- Device must not be exposed to heat sources or put in areas subject to water or humidity.
- Avoid long permanence under direct solar ray incidence.

2.3.Setup and electrical connections

Eyer® is supplied separately from the smartphone. Before first use, qualified and supplier-authorized technicians must install smartphone and application to assure the device works perfectly. Contact **Phelcom** for further information on initial setup. **Phelcom** staff may also provide remote access to make maintenance and application troubleshooting possible.

Eyer® power source is the smartphone battery. It does not have a connection to the power grid. When not in use for imaging, the smartphone can be attached to a passive mechanical-support base and connected to its original charger, facilitating battery recharge.



For charge procedures, use only original charger supplied with the smartphone, or a compliant one which follows all the applicable safety directives.



It is not possible to access the examination operation screen while the battery charges.
If the battery is completely discharged, it may be necessary to remove the battery and charge it externally with its original charger.

Figure 1 displays the device in its accessory base.



Figure 1: Device on its accessory base.



Device charge source is the smartphone USB-C 3.1 connection, which shall follow all protocol standards.

Eyer® application setup for smartphones works as the steps described in section 2.2. Minimum requirements of the smartphone follow specified in Table 1.

Table 1: **Minimum requirements for smartphone.**

Operating System	Android Nougat 9.0 Pie
Screen	6.1-inch AMOLED 1440X3640 (~550 ppi)
Processor	Qualcomm Snapdragon 885 or Samsung Exynos 9820
Storage	64 GB (UFS 2.1)
RAM	4 GB
Back Camera	12MP Dual Pixel, f/1.5 2.4-micro pixels OIS, manual control. Camera ought to be laterally centered on the smartphone.
Connectivity	Wi-Fi 802. 11ac MIMO, USB-C

Charge source	USB - C fast charging
Battery	3400mAh
Water resistance	IP 68 rating
Dimensions	149.9 x 70.4 x 7.8mm
Weight	157 g

According to minimum requirements, the most adequate smartphones available on market are Samsung Galaxy S10.

3. Eyer®

Eyer® is simple and user-friendly. Device and application details and operation flow are presented below:

3.1. Device features

Figure 2, figure 3, figure 4, figure 5 and figure 6 present the feature list below:

1. **Eyer®** Retinal Camera with integrated smartphone
2. Protective lens cap
3. Eyecap
4. Accessory base (Charging station)
5. Charger and USB cable
6. Compliant Smartphone
7. Optical body
8. Charging connection
9. Electronics compartment
10. Compliance seal and indelible label with basic information

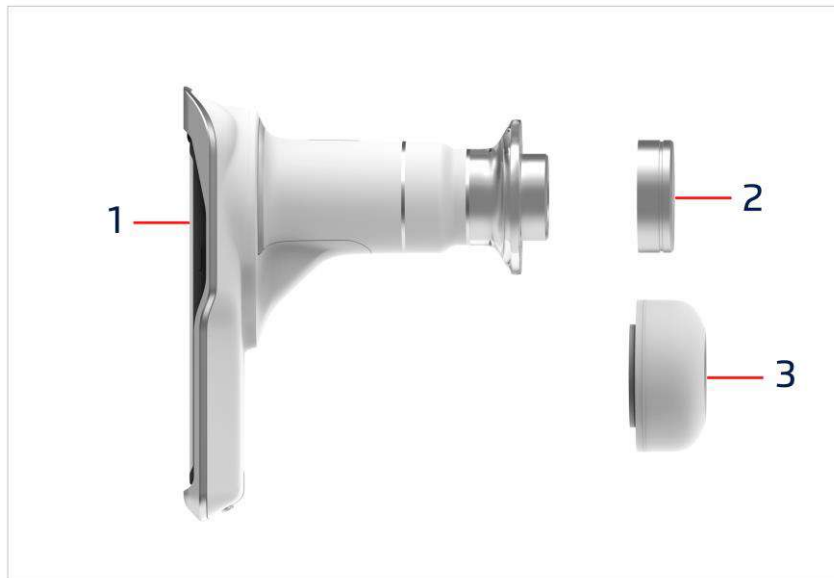


Figure 2: **Eyer®** protective lens cap and Eyecap

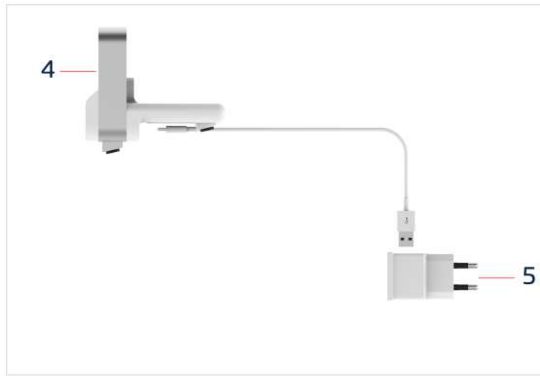


Figure 3: Base and charger



Figure 4: Back view of the system with attached smartphone



Figure 5: Front view of the device with attached Eyecap



Figure 6: Device identification label attached to the case

3.1.1. Operation

After acquiring the **Eyer®**, the user must access the Eyer application and log in. Follow the next instructions for creating your account. All operation of the device is done through the application installed on the smartphone, which is used for commands, controls, visualization of operations and results, as well as access to external systems for sharing and storing images.

The **Eyer®** operation is divided into two options: The user can create an account **or** make quick captures without being logged in. See **section 3.2.2** to create the account and see **section 3.2.3** for Quick captures.

3.2.Application

The **Eyer®** application is simple and functional. It allows patient registration, conducting and organizing exams, making reports, and editing information. Captured information and exams can be safely synchronized by SMB/CIFS, DICOM, FTP or Local Folder connections allowing the visualization of the data and exams outside **Eyer®** application. For patient data synchronization consult the section 3.2.1.3.4 Servers for details.

3.2.1. Device start screen and access

With the smartphone on, the user must wait one minute for the system to update its functions and be operable. In case of access before this timespan, a message as in figure 7 displays.

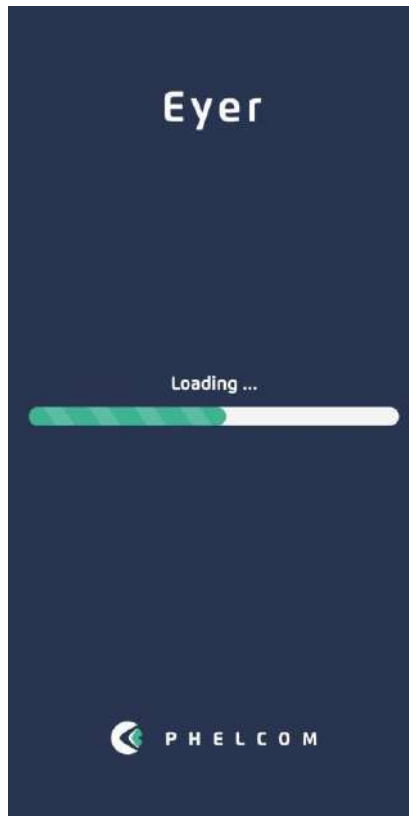


Figure 7: Startup message

After startup, drag the top android bar as shown in figure 8, it will open up the quick access tools, select the Wi-Fi option and set it up as follows in figure 9 and figure 10.

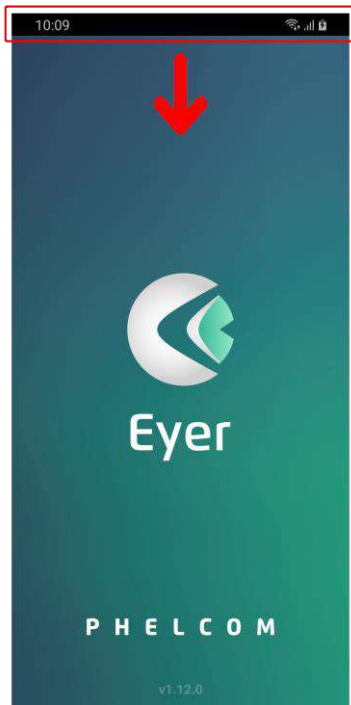


Figure 8: Device start screen with top android bar

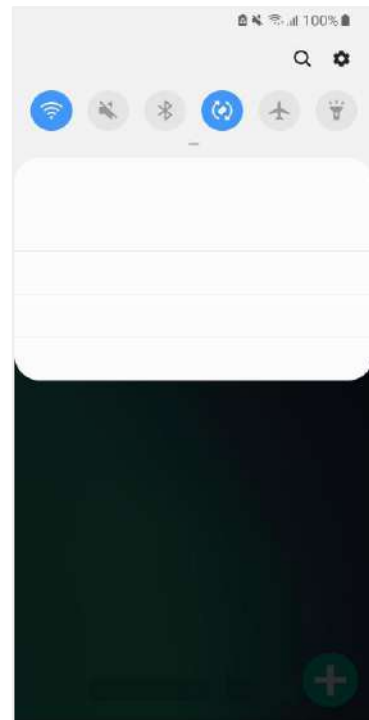


Figure 9: Quick Access Tools



Figure 10: Wi-Fi details

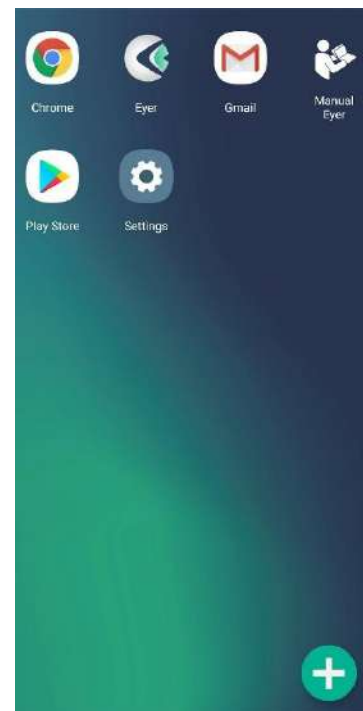


Figure 11: Quick access apps

Access application by an icon on the central screen, figure 8. Figure 12 depicts the program loading screen.



Figure 12: Initial system loading screen

A screen for USB device permission displays at the end of the process, use it as default and click "OK", figure 13 and 14. Select the language, figure 15, and the terms of use and privacy policy display, figure 16. Read them carefully before accepting.

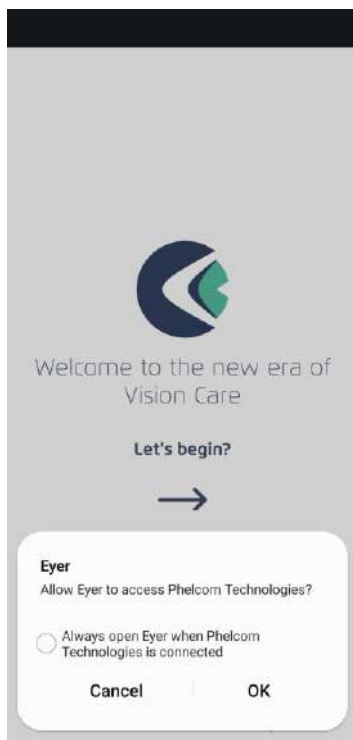


Figure 13: Setting USB device as default

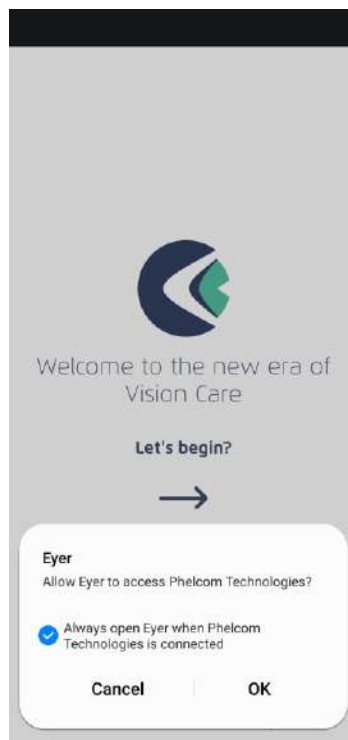


Figure 14: Setting USB device as default



Figure 15: Language selection



Figure 16: Accept Terms of Use

3.2.2. Eyer Account Creation

After accepting the terms and conditions of use, the user must create their account on **Eyer**[®]. Follow the instructions as shown in the figures below.

Figure 17: Click on Create account.

Figure 18: Fill in the requested data: Name, Last Name, Clinic Name, and Country.

Figure 19: Fill in an e-mail not registered yet and confirm the email, create a password, and confirm your password. **Note:** Provide 8 or more characters with a mix of letters, numbers, and symbols.

Create PIN and confirm. **Note:** Numeric password, will be used to access the device, Provide 4 or more digits.

WATCH THE TUTORIAL



Read the QR CODE to watch the video on your phone



SIGN IN

CREATE ACCOUNT



Figure 17 - Create Account

USER INFO



Name

Last name

Clinic name

Country



Figure 18 - User Info

LOGIN INFO



Email

Confirm email

Password



Confirm password

(Provide 8 or more characters with a mix of letters, numbers and symbols)

PIN



Confirm PIN

(Numeric password, will be used to access the device. Provide 4 or more digits)



Figure 19 - Login info

ACCOUNT VERIFICATION



A verification code was sent to the email *your_email@email.com*

0 0 0 0 0 0

CONFIRM

RESEND



Figure 20 - Account Verification

Figure 20: A verification code was sent to the user’s email. Put this code in the requested field, as shown above, and confirm.

Figure 21 below shows the email that the user will receive to fill in the previous figure 20.

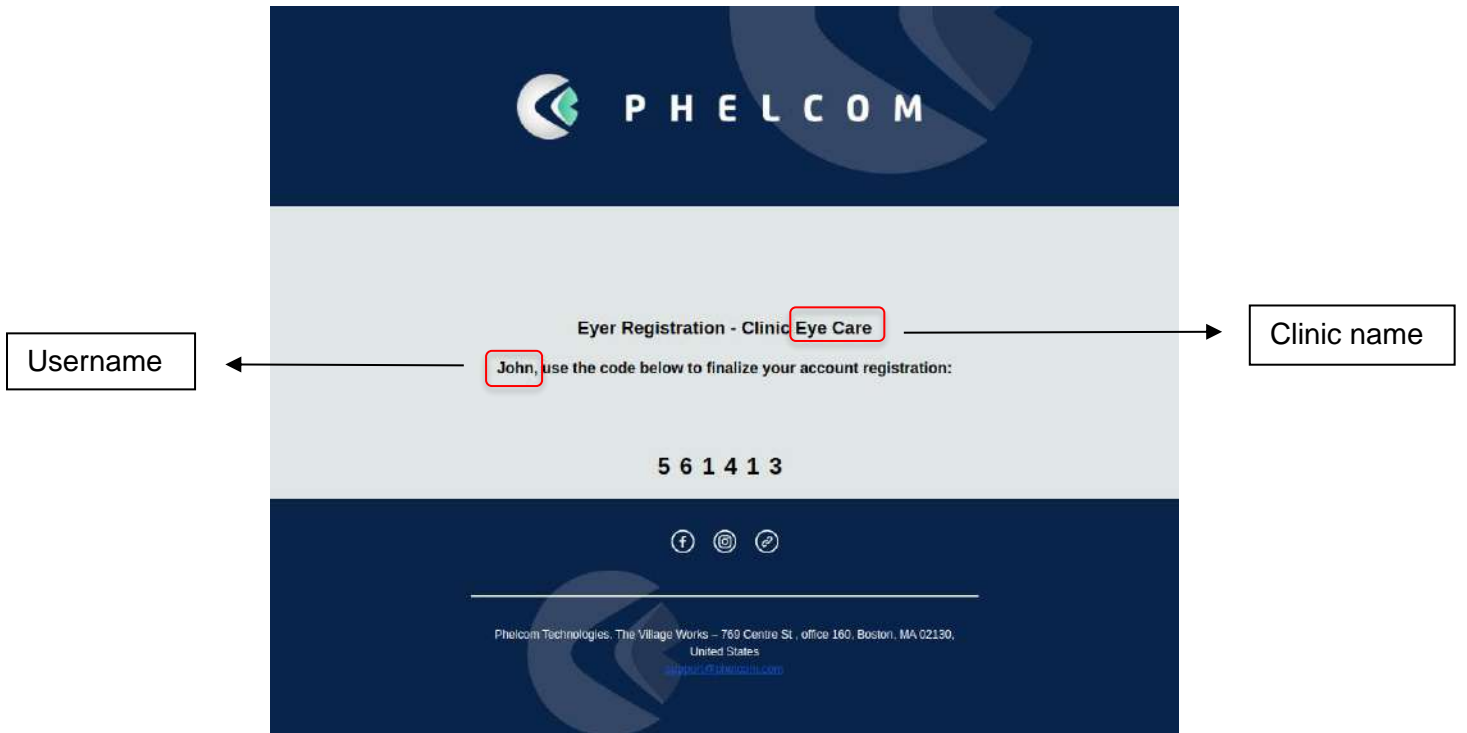


Figure 21 - Verification code in email

If, the user does not receive the verification code in the email, click on the "Resend" button, in figure 20 and a new code will be sent again.

After confirming your code on the "Account Verification" screen (Figure 20), log in with your email and password (Figure 22).

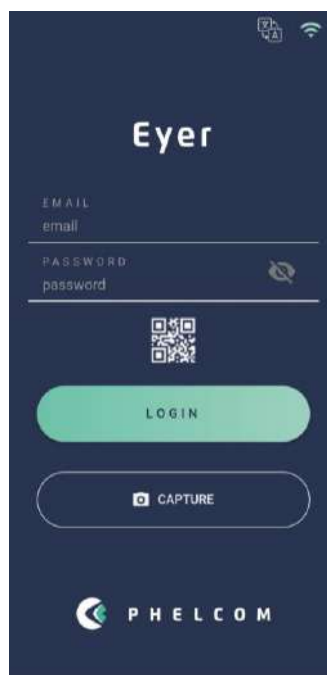


Figure 22 - login with email and password

3.2.3. Quick captures

If the user intends to make a quick capture, just to visualize the photo, you can use the basic capture screen. The user must click on “Capture” as in Figure 23:

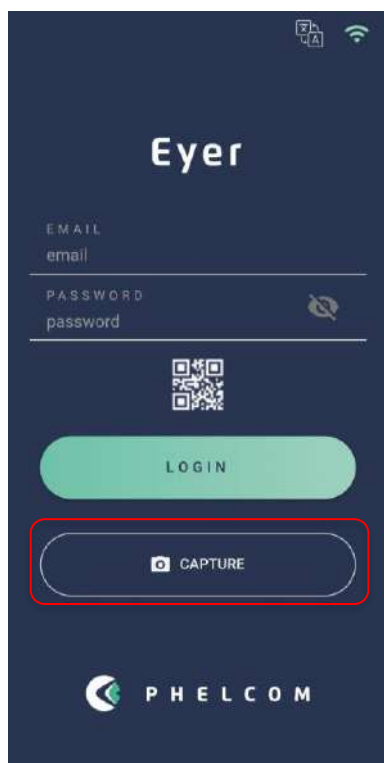


Figure 23 - Capture option to Quick Capture

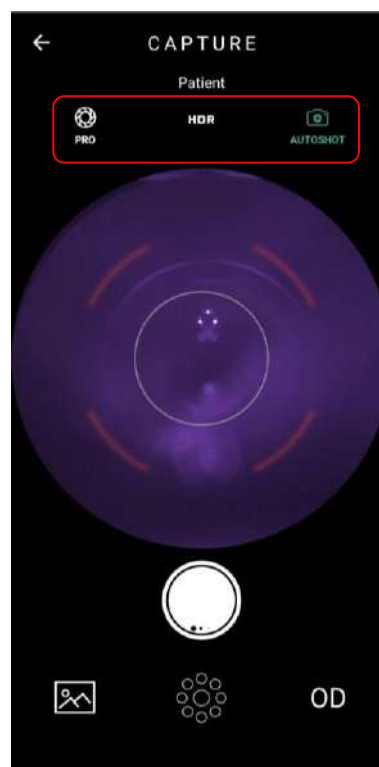



Figure 24 - Screen available for Quick capture

The screen available for Quick Capture, as shown in Figure 24, is the Basic Capture Screen. Below is an explanation of the functions:

- PRO: Navigates to full screen, with all available control options.
- HDR: Image combination with different exposures to increase the dynamic range.
- AUTOSHOT: Automatic capture. The condition for using the "Autoshot" function is that the positioning is done correctly. This function interacts with the user through the target displayed on the screen.

For more detailed Basic Capture Screen descriptions, please, see **section 3.2.1.1.2.5 - Image Capture Screen**.

To access the quick capture gallery, the user must follow these steps:

1. On the home page, the user must click on "Exams", as shown in figure 25
2. Click on the icon  , figure 26
3. Select "import exams, figure 27
4. Select the desired images, figure 28 and 29
5. Add the selected images to the respective patient, figure 29 and figure 30
6. In figure 31 in the info tab, it is possible to observe general information about the selected patient and in the gallery tab, figure 32, the transferred images are available.

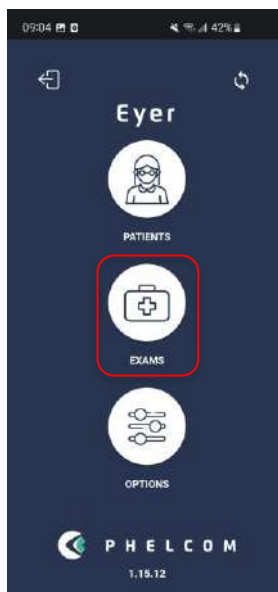


Figure 25 - Home screen - Select exams



Figure 26 - Exams screen

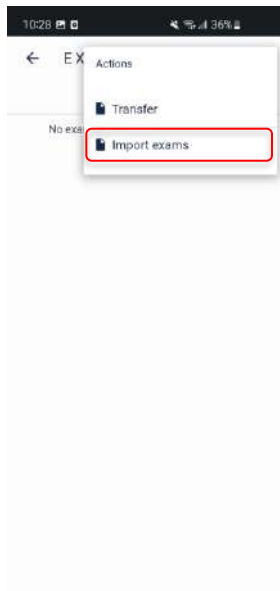


Figure 27 - Import images screen

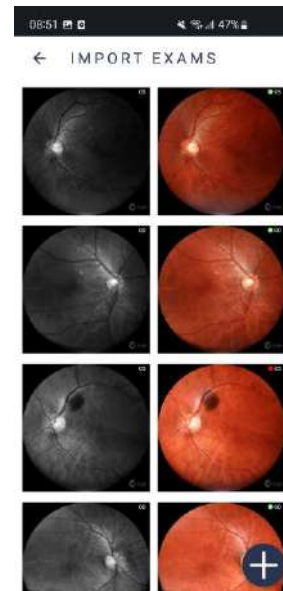


Figure 28 - Import exams screen

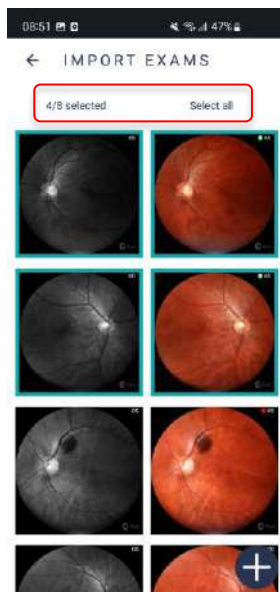


Figure 29 - Desired images



Figure 30 - Patients screen



Figure 31 - Info screen

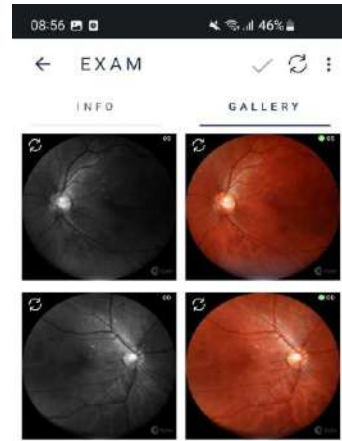



Figure 32 - Gallery screen

3.2.4. Creating patients

After login, a screen displays, figure 25. It enables accessing all system functions: patients, exams, and options. Click the synchronization icon , figure 25, to check transfer status, figure 33.

SEND			
	SUCCESS	FAILURES	TOTAL
PACIENT	0	0	0
EXAMS	0	0	0
REPORTS	0	0	0
IMAGES	0	0	0

0 kb/s


All records have been synchronized.

Figure 33 – Device transfer status


3.2.4.1. Patients

Access option 1, "Patients", in the main screen, figure 25, to register, visualize, alter information, as well as carry out exams and diagnostics through patient information.

3.2.4.1.1. Creating patient profiles through Eyer®

Selecting icon 1, figure 25, displays a screen as in figure 34. Here, a list of registered patient names displays. Activate button  and insert patient information. Highlighted fields in figure 35 must be filled in.

1. Name
2. Surname
3. MRN - Medical Record Number (Optional)

Click the icon  to save information and automatically create a registration form for the patient.



When the spherical equivalent of the patient is inserted in the field "spheric diopter" in his/her registry, focusing is automatic when the capture screen opens.

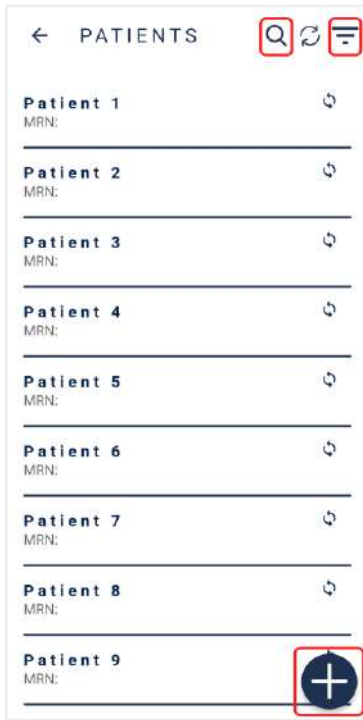


Figure 34: Opening screen for the "PATIENTS" option, figure 25



Figure 35: Screen for creating patient profile



Click  to sort the profiles list and choose one option: recent, ascending or descending, figure 36.



Figure 36: Filter to exhibit patient profiles

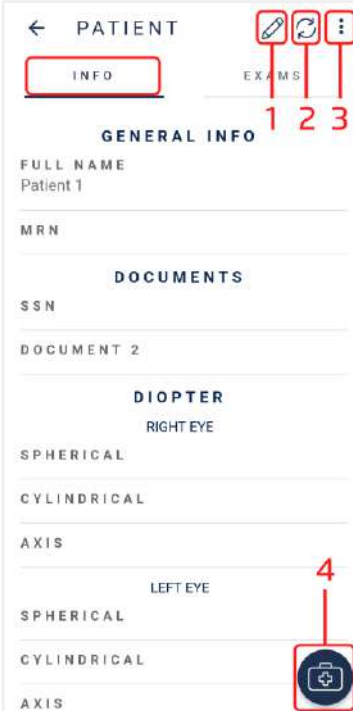
3.2.4.1.2. Patient personal information

Figure 34 depicts the screen to access information from registered patients. They are shown as a list the user can search by name, using the icon , or by scrolling the screen. A registration form is created for each patient, with personal and technical information, as well as captured images.

3.2.4.1.2.1. Info

Each patient registration form, figure 37, is accessible through the screen depicted by figure 34, or automatically, after creating a new patient profile (section 3.2.1.1.1 Creating patient profiles through **Eyer®**). First provided information is compiled in the “info” tab, with the following functions:

1. Edit information
2. Synchronization
3. Options
4. Create a new exam (section 3.2.1.1.2.4 Creating exams through **Eyer®**).



The screenshot shows a mobile application interface for patient information. At the top, there's a header 'PATIENT' with a back arrow on the left and three icons on the right: a pencil (labeled 1), a refresh (labeled 2), and a list (labeled 3). Below this is a navigation bar with 'INFO' (highlighted with a red box), 'EXAMS', and a menu icon. The main content area is divided into sections: 'GENERAL INFO' with fields for 'FULL NAME' (Patient 1) and 'MRN'; 'DOCUMENTS' with fields for 'SSN' and 'DOCUMENT 2'; and 'DIOPTER' with sub-sections for 'RIGHT EYE' and 'LEFT EYE'. Each sub-section has fields for 'SPHERICAL', 'CYLINDRICAL', and 'AXIS'. A red box labeled 4 highlights a plus icon in the bottom right corner, which is part of a magnifying glass icon.

Figure 37: Patient registration form in “info” tab.

3.2.4.1.2.2. Removing a patient profile through Eyer®

Select icon 3, figure 37, to remove a patient form. Click the “remove” option in checkbox, figure 38. Do not select “remove remote” to remove the capture from Eyer® and keep it on your servers, figure 39. Select “remove remote” to remove it from all places, figure 40.



Figure 38: Option to remove patient profile



Figure 39: Remove patient profile from Eyer®



Figure 40: Remove patient profile from Eyer® and configured servers

3.2.4.1.2.3. Exams




Figure 41 depicts each patient registration form, which contains the tab “exams”. It displays a list with exams sorted by date, hour, status (closed or open) and possible images or reports in the exam. Icon  creates an exam for the current patient profile.



Figure 41: Exams tab

3.2.4.1.2.4. Creating exams through Eyer®

Select icon  in “info” or “exams” tab, figure 41, and the screen in figure 42 displays. “Info” tab contains the patient’s name, date, and time of exam (click in any section field to edit), a field to write notes and a selector switch for patients with mydriasis. Icon  opens the image capture screen.

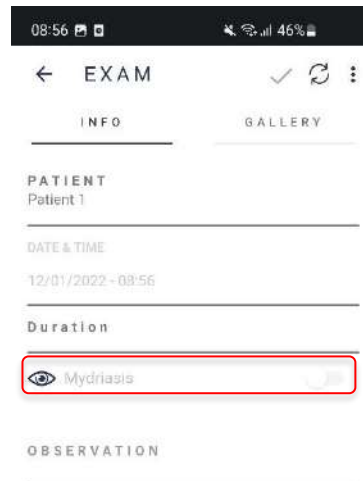


Figure 42: Information to create a new exam



3.2.4.1.2.5. Image capture screen


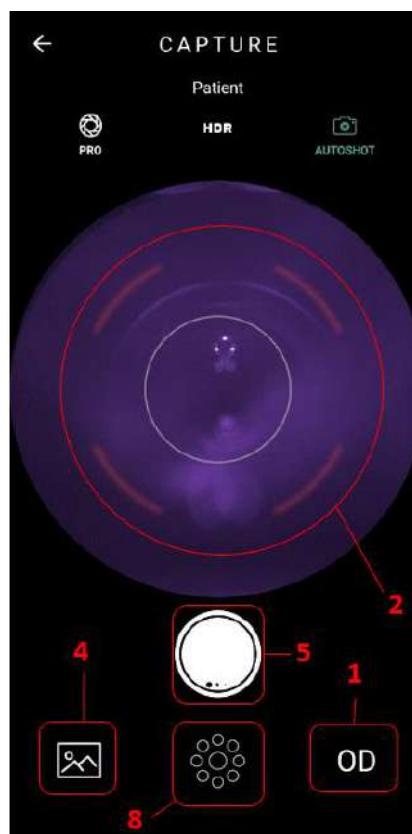
Select icon , figure 42, and a screen, figure 43, opens. Its icons are specified according to their functions.

Figure 43: Image capture screen



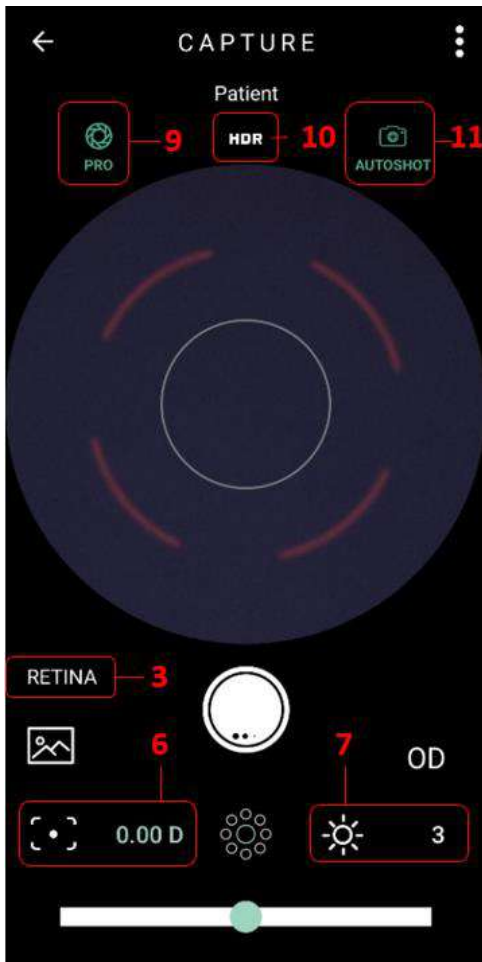


Figure 44: Fixation targets

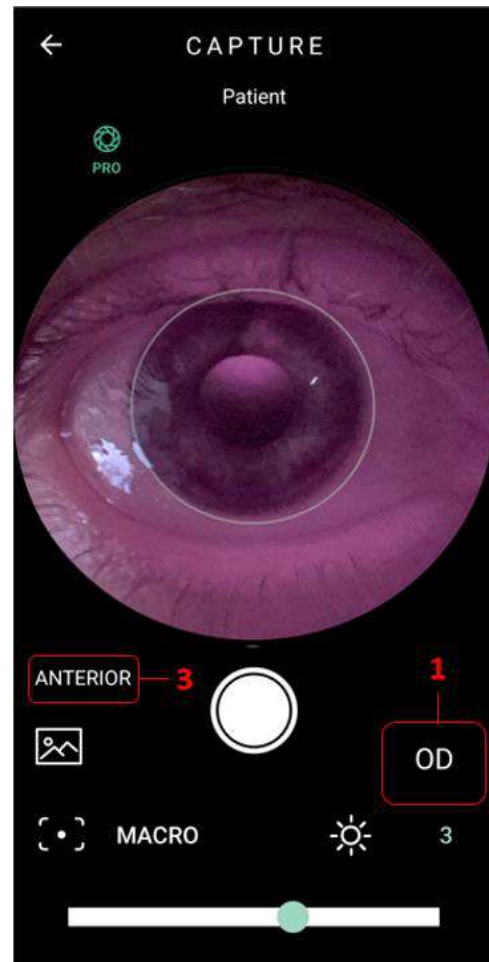


Figure 45: Anterior segment capture screen – Pro Mode

1. Eye selection

- 1.1 OD Indicates the right eye of the patient is examined.
- 1.2 OS Indicates the left eye of the patient is examined.

2. Autofocus

Exams without knowledge of the patient's diopter demand positioning the device (same procedure to carry out an exam as in section 4. Carrying out exams) and touching on the optic nerve image in the image display screen.

Patient will see a white light flash. There is no image capture at this point, but the device will adjust focus of the examined eye. Remove **Eyer**[®] from the patient's face. It is possible to photograph after a few seconds if the pupil is not dilated with eye drops.

3. Segment Selection

3.1 RETINA - Indicates image capturing of the posterior segment.

3.2 ANTERIOR - Indicates image capturing of the anterior segment. This function has fixed parameters. It is only necessary to select the eye to be examined, figure 43.

4.  **Exams image gallery**

5.  **Image capture**

6.  **Manual focus**

Select the icon and drag the adjustment bar towards the aimed value to inform the patient’s spherical diopter equivalent.




Image focus follows patient's spherical equivalent.

7.  **Lighting adjustment**

Lighting scale varies from 1 to 5.

Click the icon  to adjust lighting through the adjustment bar.

Adjusted Level	Emitting Light level	Camera Gain	Indication of use	Functional characteristics
1	LOW	100%	Very clear eyes or retinal tissues with high reflection abnormal structures in the back of the eye may require this adjustment if they are white or bright color	Dark photos suitable for light colored retinal structures
2	MEDIUM	100%	Clear eyes and standard	Increase contrast

			retina	and definition of details in clear structures such as the optic nerve head
3	HIGH	100%	Standard setting	Ideal for taking the first image capture and checking the need for adjustment
5	HIGH	120%	Dark eyes or with opacity in the anterior tissues of the eye-crystalline or vitreous	First adjust when the photo is dark in the default setting
5	HIGH	150%	Very dark eyes, or intense opacity	The gain is increased, and the image quality may decrease in darker regions



Set lighting level to 1 for glaucoma or glaucoma suspect patients.

8.  Internal fixation target selects

By clicking the icon, 9 circles display on the capture screen, figure 31. Internal fixation target determines which eye area is centered while capturing the image. The larger circles portray: macula (center) and optical nerve (left for left eye capture; right for right eye capture).

As images are captured from different fixation targets, the greater the visual field covered in the exam. It is advisable to hide the targets for capturing the images (click the icon again).

9. Function PRO

The function PRO navigates to full screen, with all available control options. See figure 45.

10. Function HDR



This function is the image combination with different exposures to increase the dynamic range.

11. AUTOSHOT Function

Automatic capture. The condition for using the “Autoshot” function is that the positioning is done correctly. This function interacts with the user through the target displayed on the screen.

3.2.4.1.2.6. Captured images

Select the tab “Gallery”, figure 42, to view captured images, figure 46.

Click the icon  , figure 46 to share images, send manually via DICOM/FTP/SMB; click the icon  , figure 46, to create panoramic images, texture or stereo and/or remove images in bulk. An action box opens, figure 47.

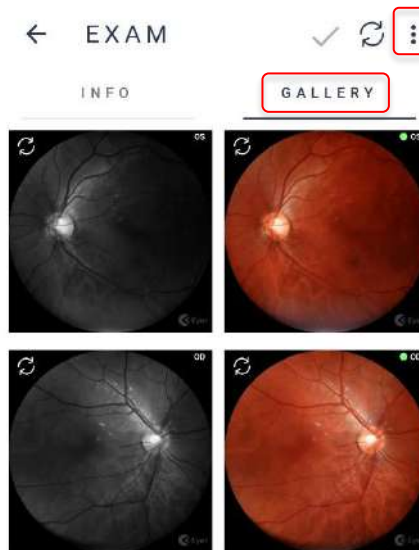


Figure 46: Images captured during exam

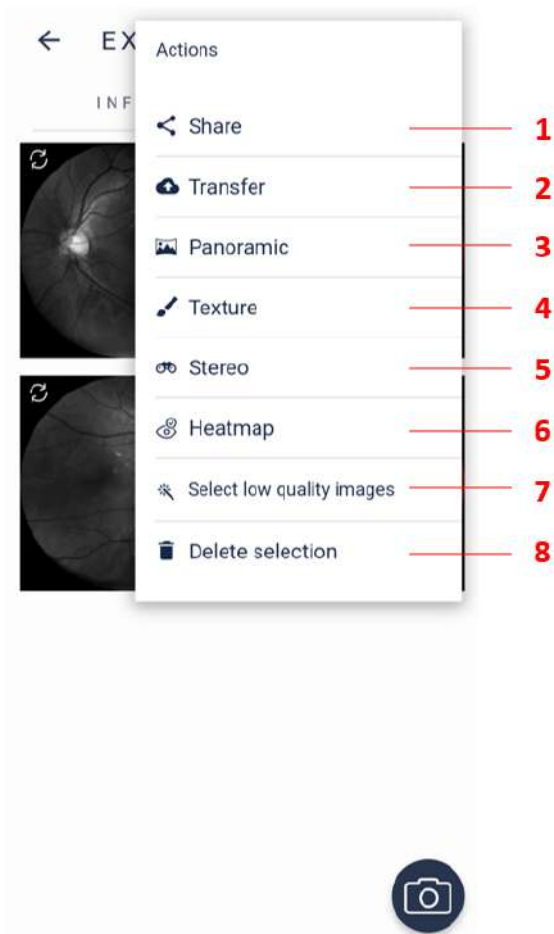


Figure 47: Checkbox for images

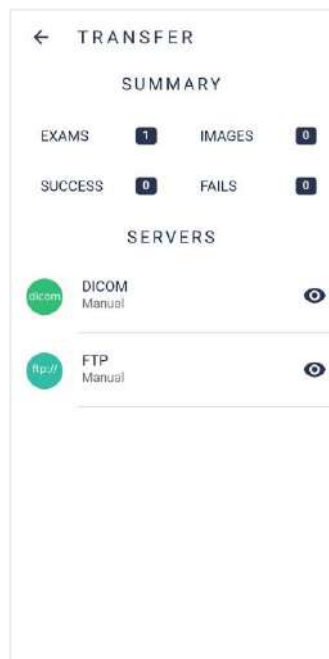

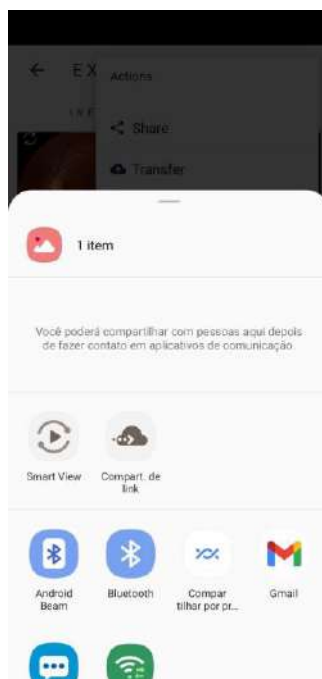



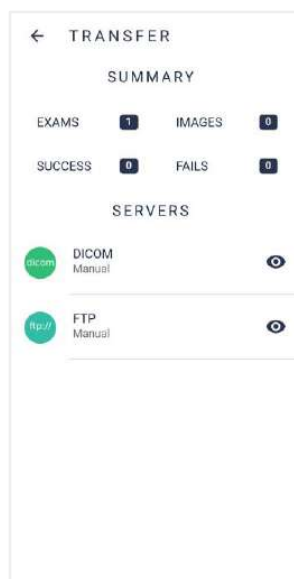
Figure 48: Screen for sending image via DICOM/FTP


- 1. Share:** Sends images to external platforms. Click and hold on the images to select until a blue square frame shows around them. Click the icon , then "share" and choose how to send the file.

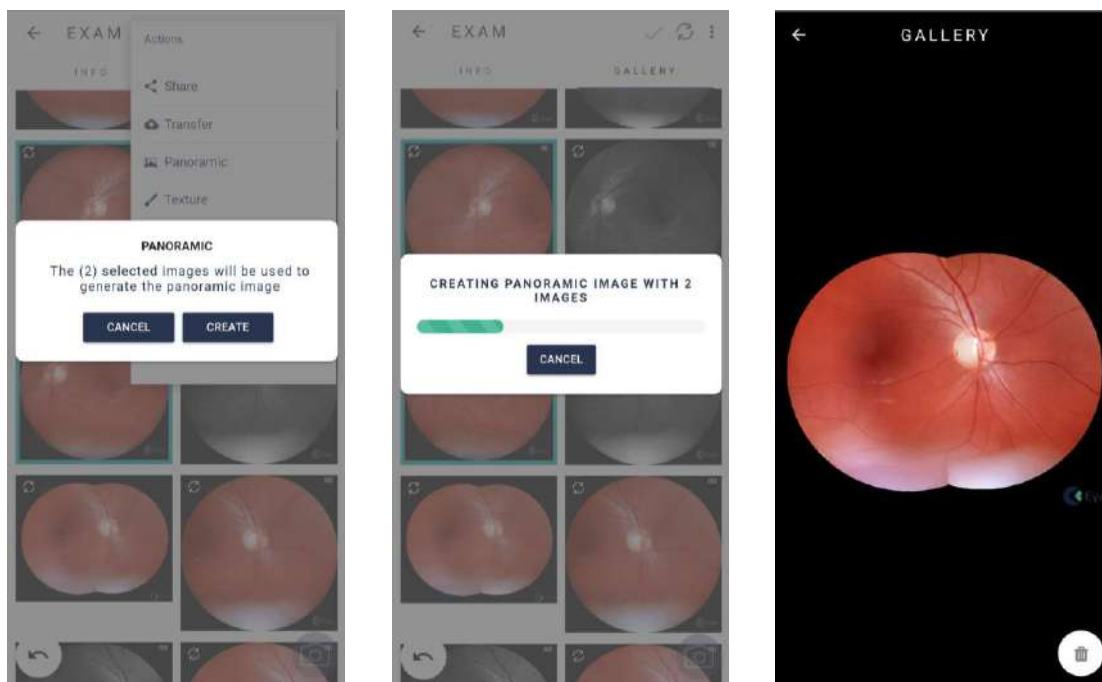



2. **Transfer:** Screen which presents a summary of exams and images to send, with success and failure statistics and the available server list, figure 48.

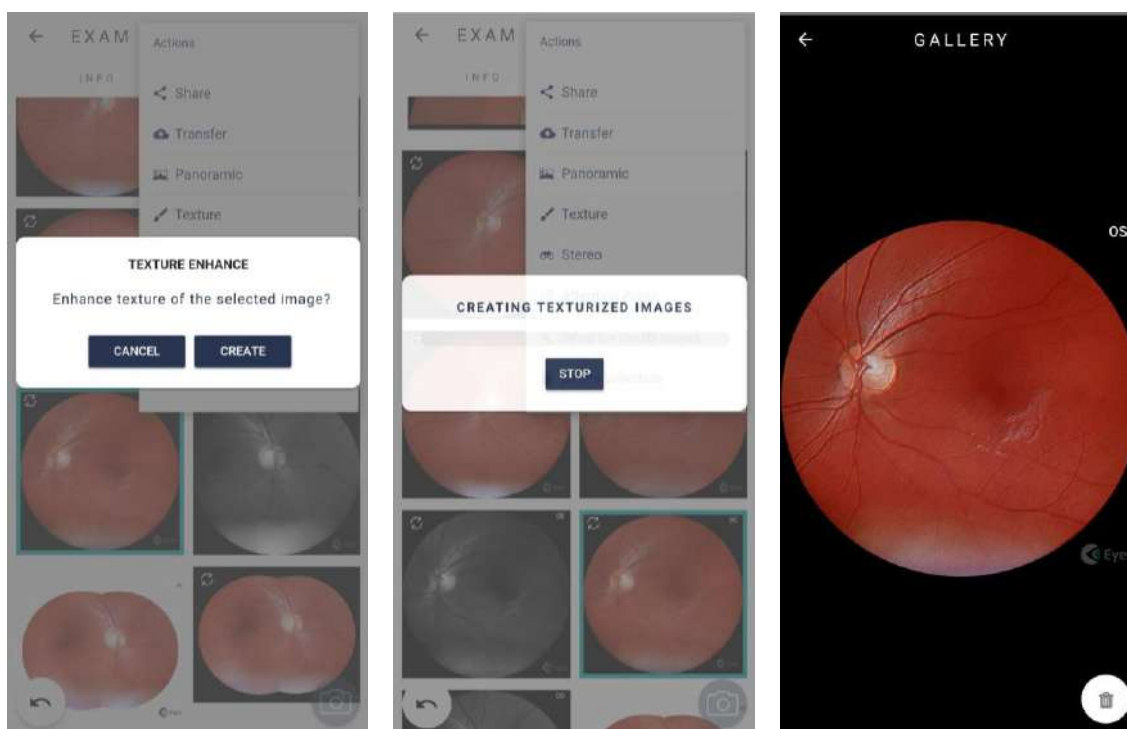
Click the icon  , then “transfer”, figure 47, then select preferred server, figure 48.




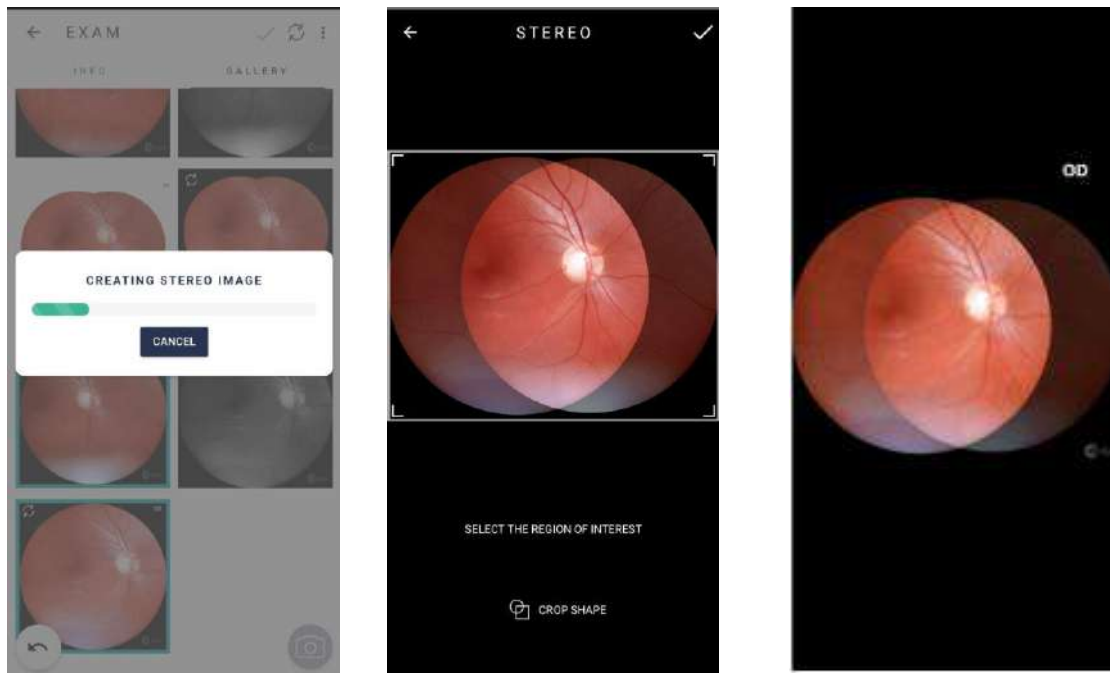
3. **Panoramic:** Set of compiled images, created from the selection of two or more fixation targets. Variety of fixation targets equals a wider analysis area. Click and hold over targeted images, then a blue square frame shows around them. Click  , then panoramic. Confirm generation and wait.




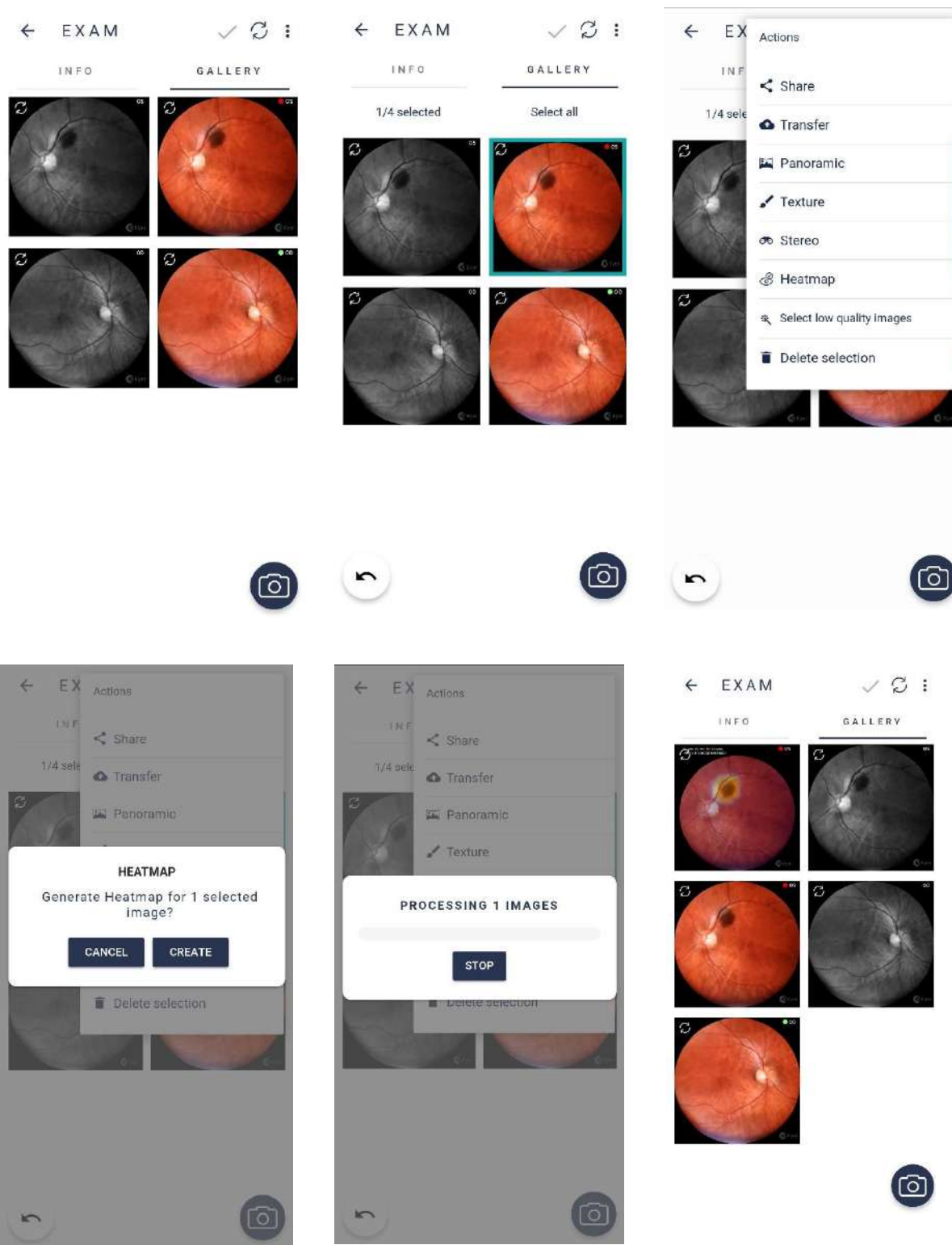
- Texture:** images with filters to assist identifying lesions. Click and hold over targeted images, then a blue square frame shows around them. Click , then texture. Confirm generation and wait.




5. **Stereo:** dynamic image that enables better viewing of the optic nerve. Click and hold over targeted images, then a blue square frame shows around them. Click , then stereo. Confirm generation and wait.

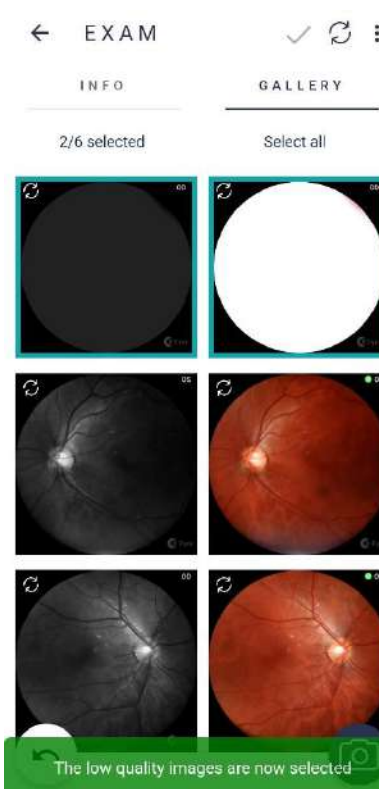
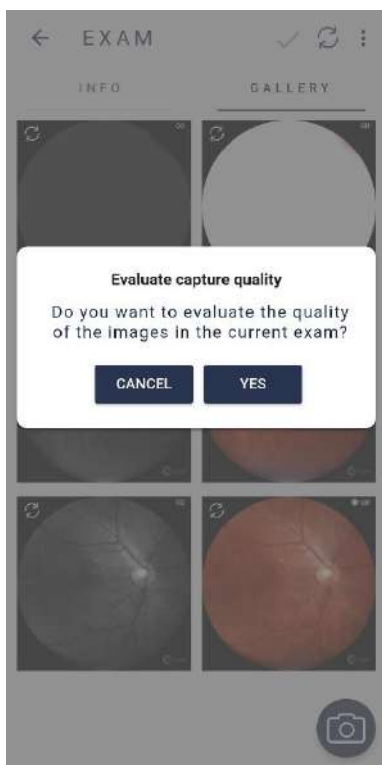
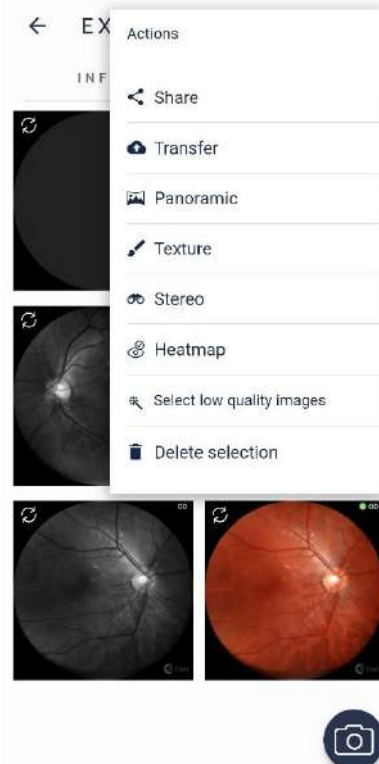
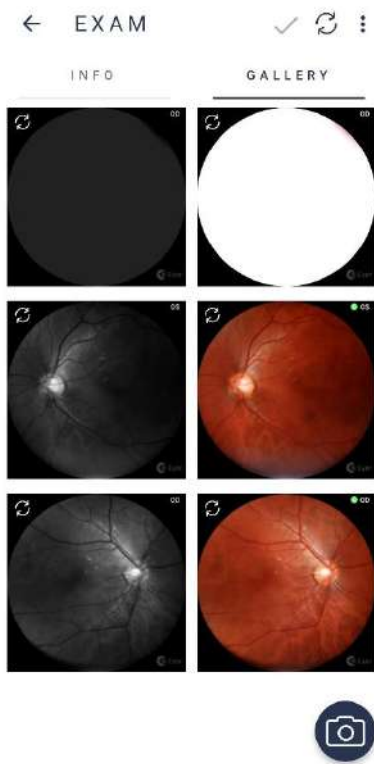


6. **Heatmap:** Data visualization mode that highlights regions of retinal changes. Medical evaluation is required. Click and hold over targeted images, then a blue square frame shows around them. Click , then heatmap. Confirm generation and wait.



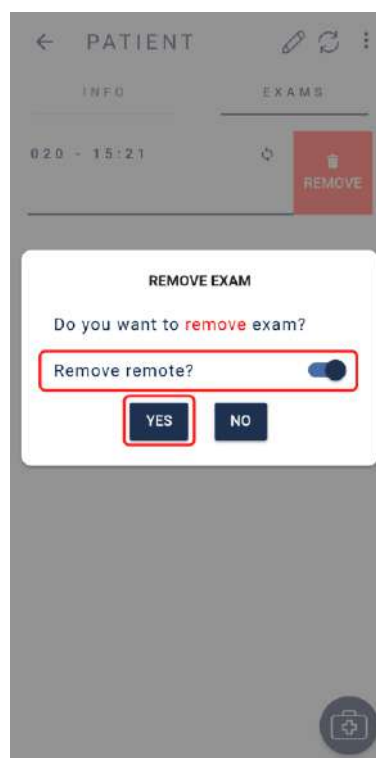
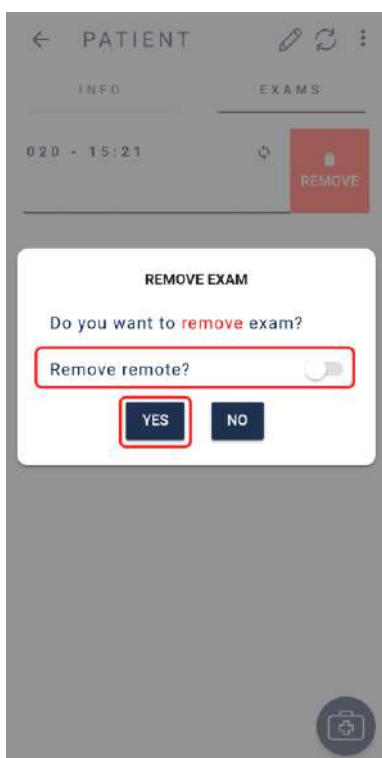
7. Select low quality images

Click and hold over targeted images, then a blue square frame shows around them. Click  , then Select quality images. Confirm generation and wait.




8. Delete images: Permanently delete an image or set of images. Check section 3.2.1.1.2.8. Removing Images through **Eyer®** to delete a magnified image.

Click and hold over targeted images to remove, click the icon , then “Delete images”, then “yes”.



3.2.4.1.2.6.1. Synchronization failure

In case of exam synchronization failure, the symbol , figure 49, displays. Click the icon to check the cause. "Synchronization Status", figure 50, displays pointing server and send errors. Touch the message in red and check synchronization details for further information, figure 51.

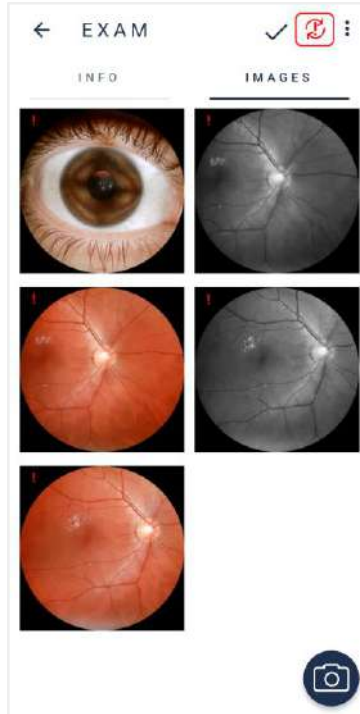


Figure 49: Synchronization failure

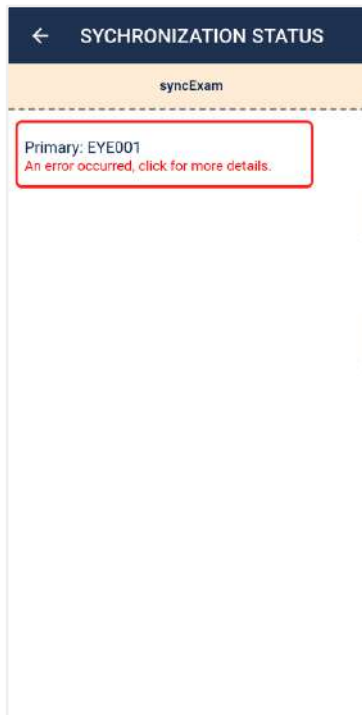


Figure 50: Synchronization details

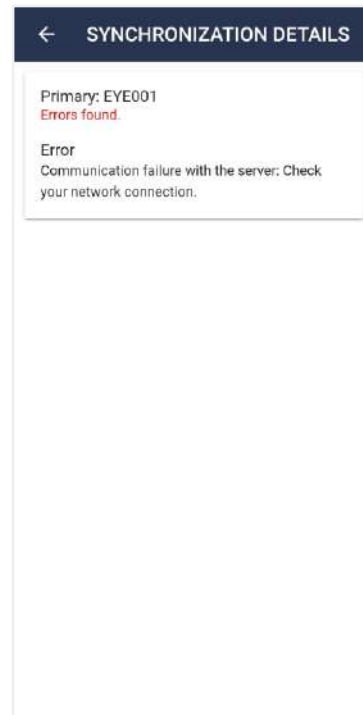



Figure 51: Synchronization status

3.2.4.1.2.7. Image analysis and editing through Eyer®

Click the capture of interest to analyze images via device. A screen with expanded view displays, figure 52. Use icon  to edit.

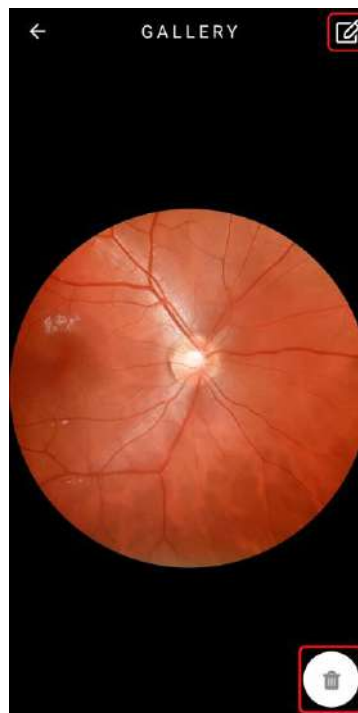




Figure 52: capture expanded image

3.2.4.1.2.7.1. Cropping

Select icon  to crop an image and choose a rectangular or elliptical shape, then drag it to the area of interest, figure 53. Complete the crop through icon .

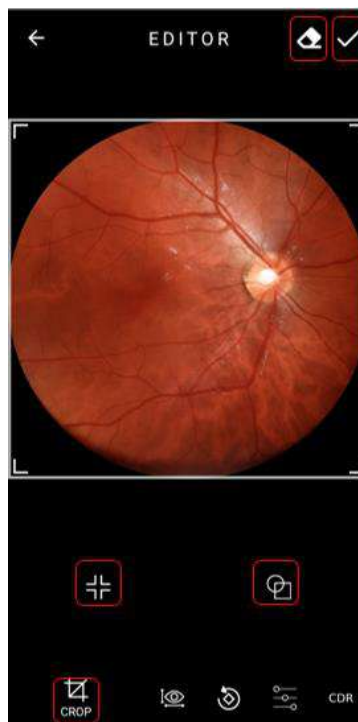


Figure 53: Editing on clipping screen

3.2.4.1.2.7.2. Image Measurement



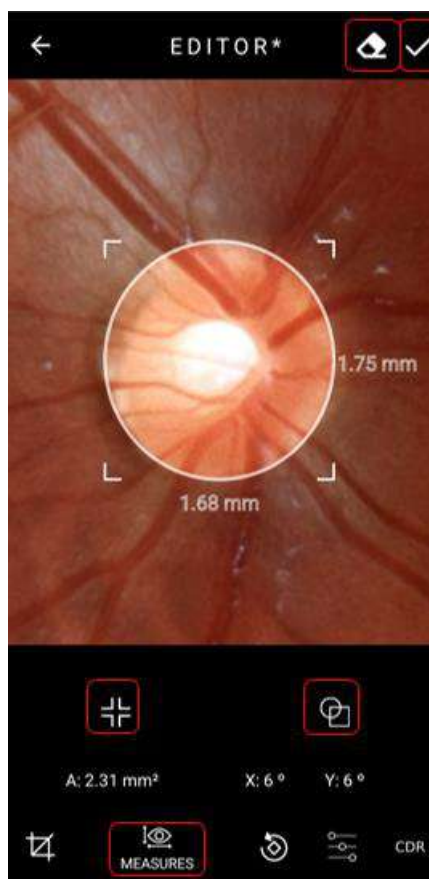
Click the icon  to measure images. Rectangular and elliptical shapes are available, figure 54. Click the icon  to complete.

Figure 54: Image measures screen



3.2.4.1.2.7.3. Image Rotation



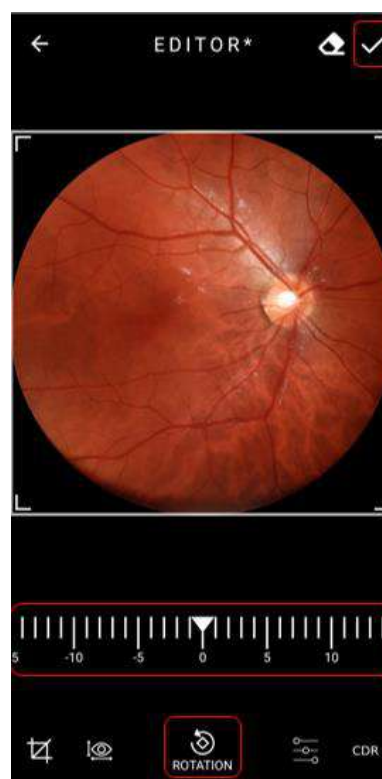
Select the icon  and drag the scale towards the aimed direction to rotate an image, figure 55. After completing, select the icon .

Figure 55: Image rotation screen



3.2.4.1.2.7.4. Levels

Drag the icon ☀ scale bar to adjust image brightness level or icon 🌑 to adjust contrast, figure 56. Select icon ✓ when complete.

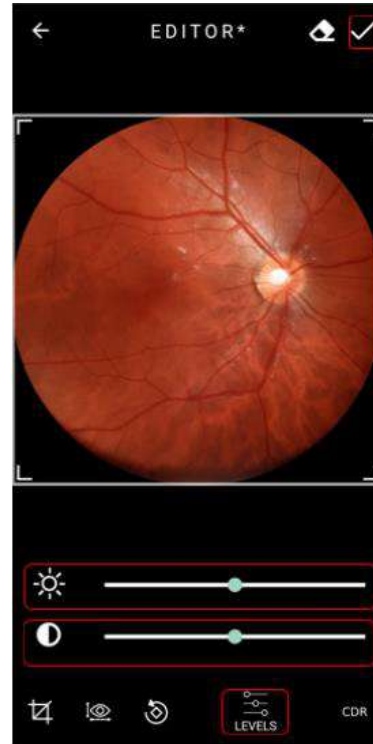


Figure 56: Image levels screen

3.2.4.1.2.7.5. ISNT Function

The user must click on the CDR (Cup Disc Ratio) button to open the ISNT (Inferior-Superior-Nasal-Temporal) function, figure 57.

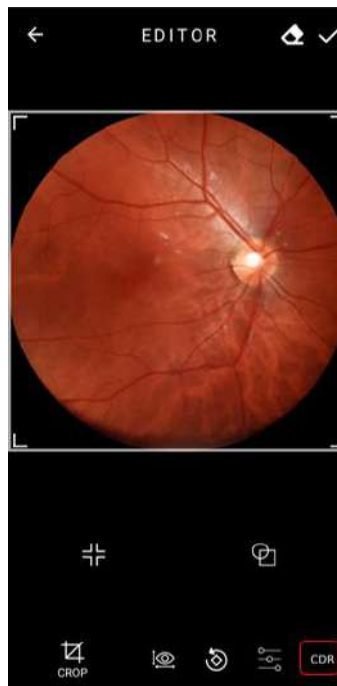


Figure 57: CRD (Cup Disc Ratio Button)

First, the user must select the intended region and a graph will be generated below, as shown in Figure 58.

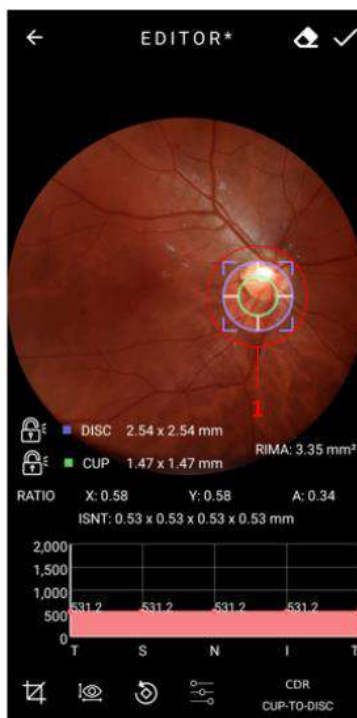


Figure 58: ISNT Graph generated

The user can use the closed padlock tool to fix one region or another. It is possible to analyze this through figures 59 to 62.

To delete the generated graph, the user must click on the button highlighted in the figure 63.

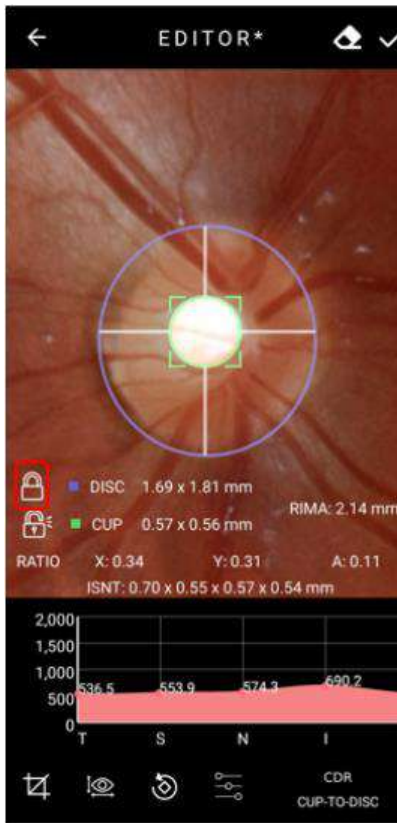


Figure 59: Padlock demonstrate

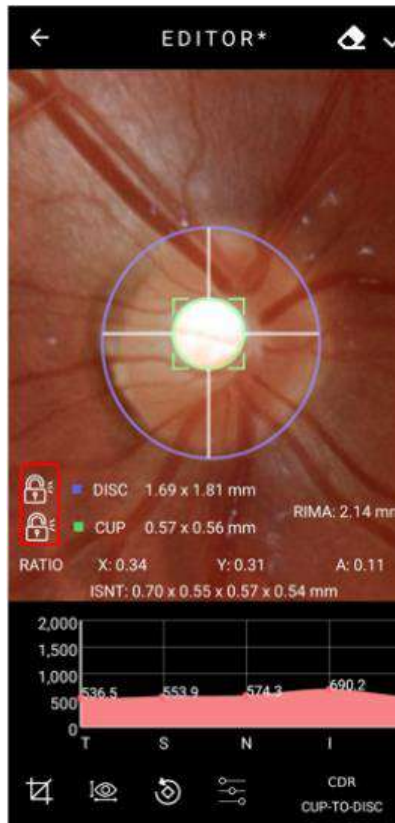


Figure 60: Padlock demonstrate

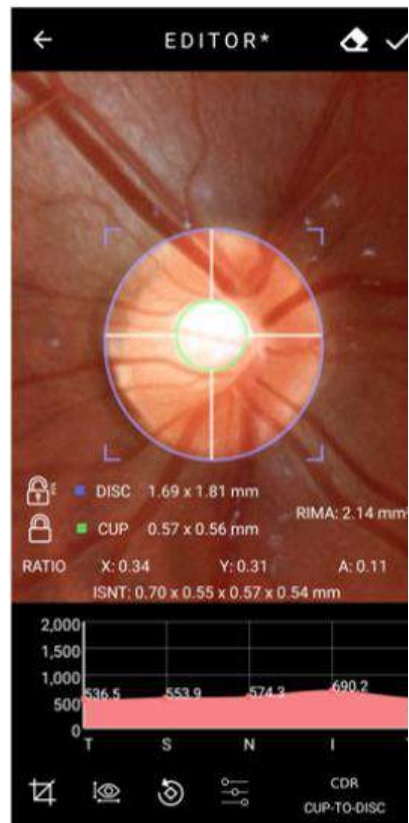


Figure 61: Padlock demonstrate

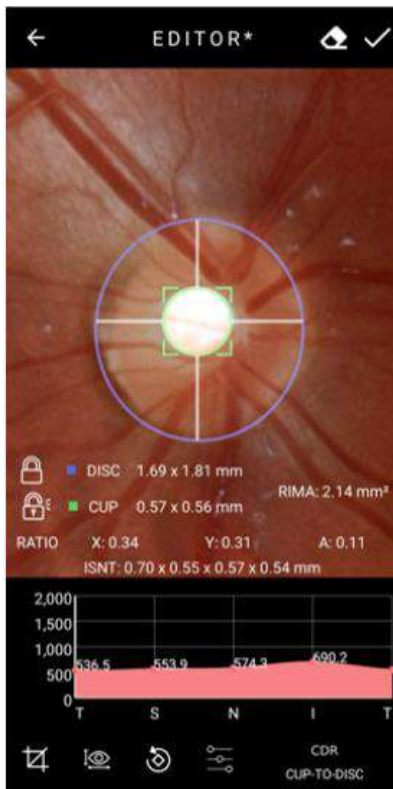


Figure 62: Padlock demonstrate

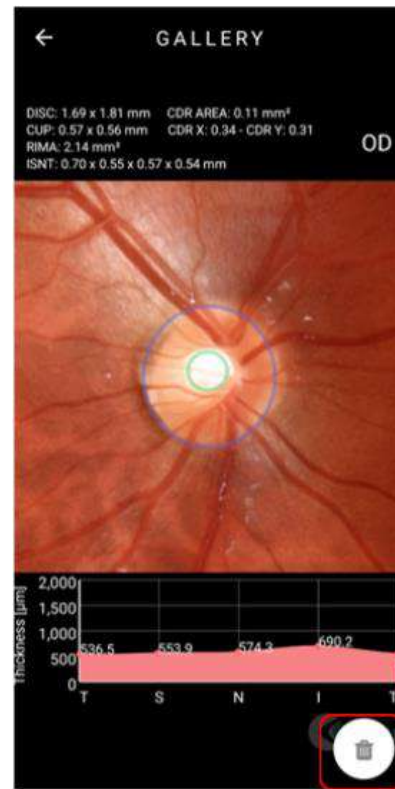



Figure 63: Delete option

3.2.4.1.2.8. Removing images through Eyer®

Click on an image to expand it, figure 41, then click  and confirm. It is not possible to recover an image after deleting it.

3.2.4.1.2.9. Removing exams through Eyer®

In the patient exams list, figure 54, slide leftwards and select “remove”, figure 64. Do not activate “remove remote”, figure 65, to delete the exam only from **Eyer®** and not from other configured servers. Activate it to delete from all servers, figure 66.

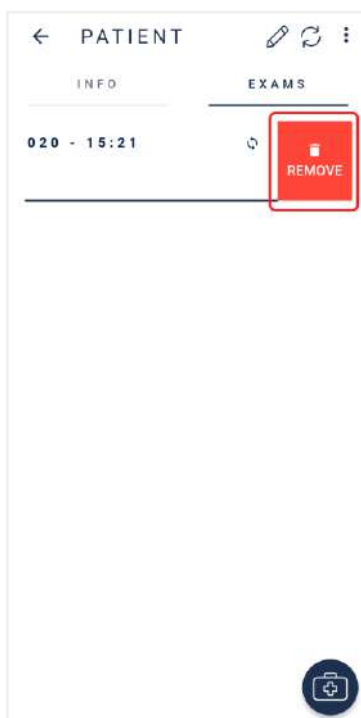


Figure 64: Removing exam

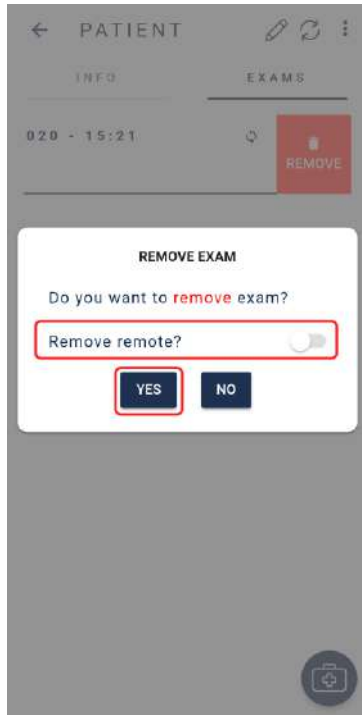


Figure 65: Removing exam in Eyer®

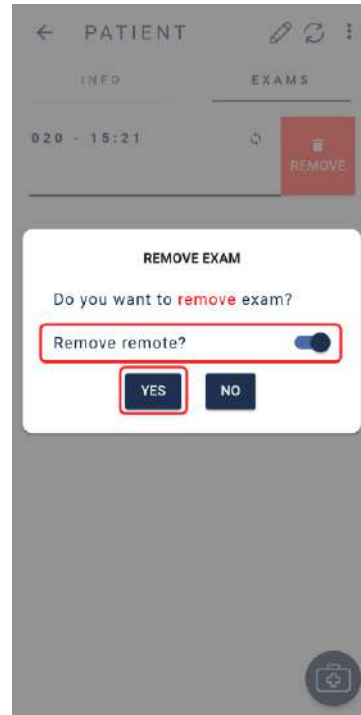


Figure 66: Removing exam in Eyer® and configured servers

3.2.4.1.2.10. Creating and editing diagnosis through Eyer®


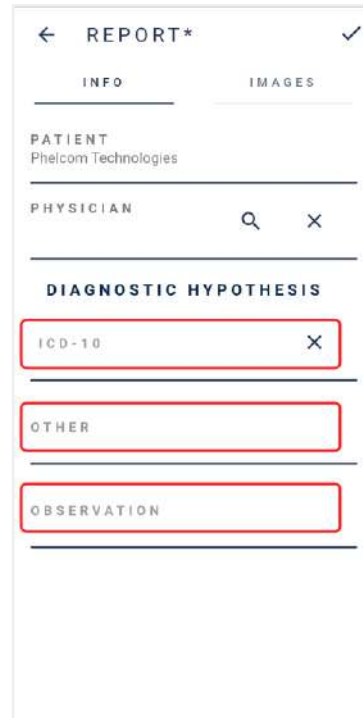
After image capture, "Info" tab, figure 42, enables the field "diagnosis" to insert technical reports, figure 67. Icon  creates a diagnosis.



Figure 67: Creating diagnosis for present exam

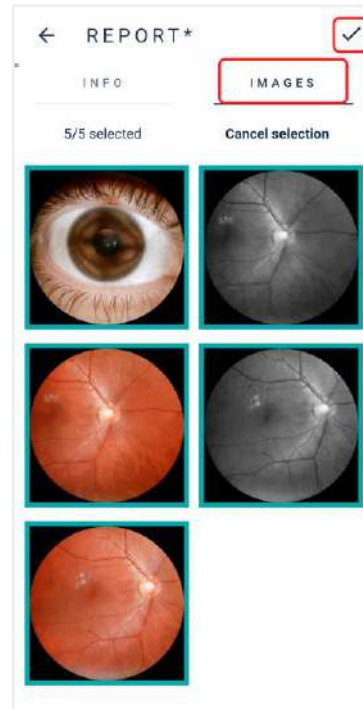
When a diagnosis is created, the screen portrayed in figure 68 opens in the “info” tab. Include, in the editable field “Diagnostic Hypothesis”, the disease hypothesis in the field “ICD pattern” and, for non-catalogued diseases, use the field “other”.

Figure 68: Diagnosis information input



All images will be selected in the “images” tab, figure 69. To prevent specific captures from appearing in the report, press it until the blue frame does not outline it. Repeat the procedure with stereo imaging. Press ✓ to complete the report.

Figure 69: Registered images to select technical report



Report file will display below the diagnosis field, figure 70:

1. Send report to one of the configured servers
2. Edit report information
3. Generate file and
4. Delete diagnosis.

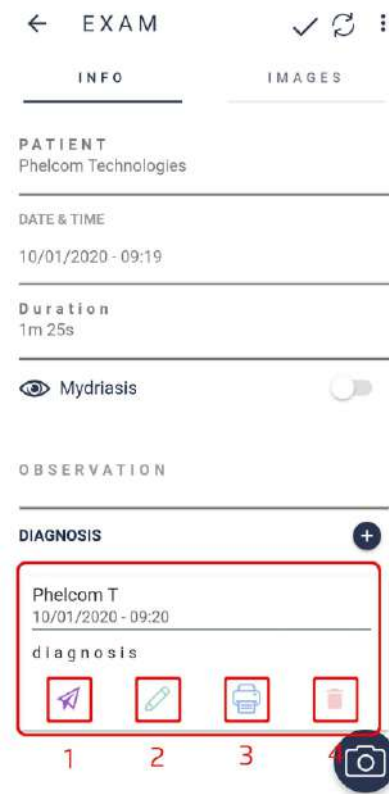



Figure 70: Diagnosis linked to the exam

Screen portrayed in figure 71 displays when icon  (generate report) is selected. The icons represent:

1. Search text in file
2. Send file, open with, download, print or report a bug, figure 72

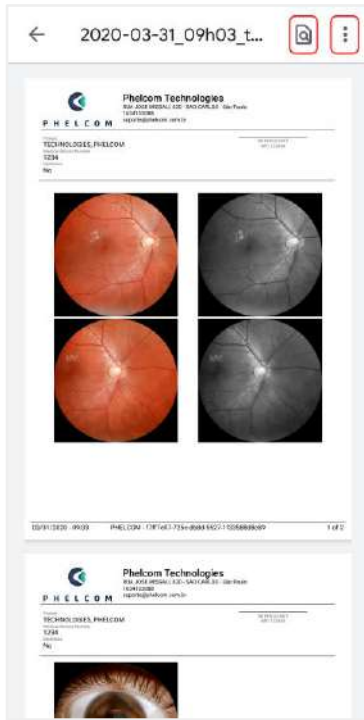


Figure 71: Application-generated report

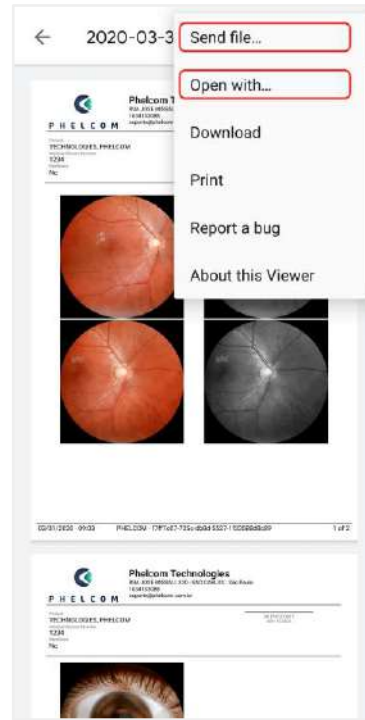


Figure 72: File options

3.2.4.1.2.11. Sending files by email

Access “Send file”, figure 72, then choose “Gmail” option, regardless of the user’s email server, figure 73, and follow application instructions.

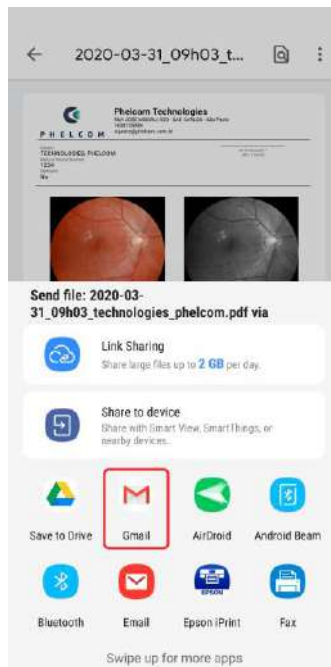


Figure 73: Sending files by email

3.2.4.1.2.12. Device printer setup

Access “open with”, figure 72, choose the local printer application, figure 74, and follow the instructions. A Wi-Fi printer is required and must be turned on to show in the available printers list.

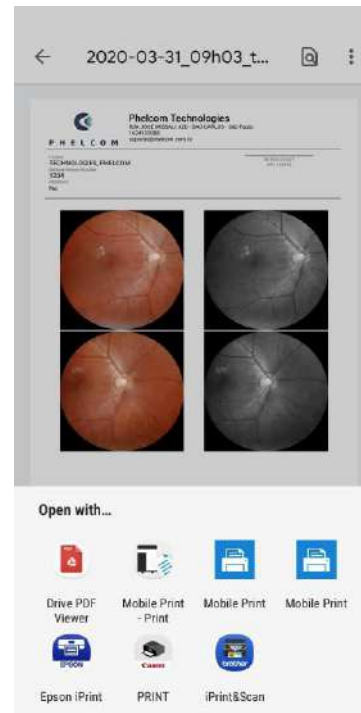


Figure 74: Print PDF

3.2.4.2. Exams

Exams may be consulted as in section 3.2.1.1.2.2 Exams or by any other direct way, as the start screen, figure 25, icon 2. When directly activated, a list of patients scheduled for the present date displays, figure 75, according to the schedule. Click the date and choose the date to check or edit.

Exams are organized in ascending chronological order. “Open” status means the exam was created but not completed; “closed” status indicates the exam is completed. The icons represent:

- 🔍 search patientf
- ↻ synchronize information
- ⋮ synchronize exams with another server

After opening the patient registration form, the user accesses the screen portrayed in figure 42. Operation procedure is the same.



Figure 75: Exams on a specific date.

3.2.4.3. Options

Option 3 on the application start screen refers to the “options” button, figure 25, which enables visualizing information on the clinic, system, device, and servers, figure 76.

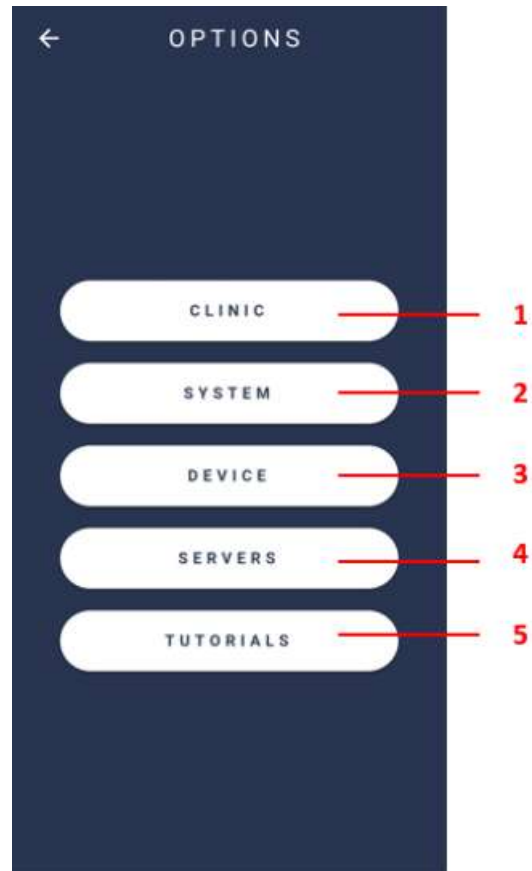


Figure 76: “Options” tag available functions.

3.2.4.3.1. Clinic

Option 1. "Clinic", figure 76, displays information on the accessed clinic, figure 77.



Figure 77: Clinic information.

3.2.4.3.2. System

Option 2. "System", figure 76, displays options to visualize system logs, default settings and language, as well as terms and conditions, figure 78.

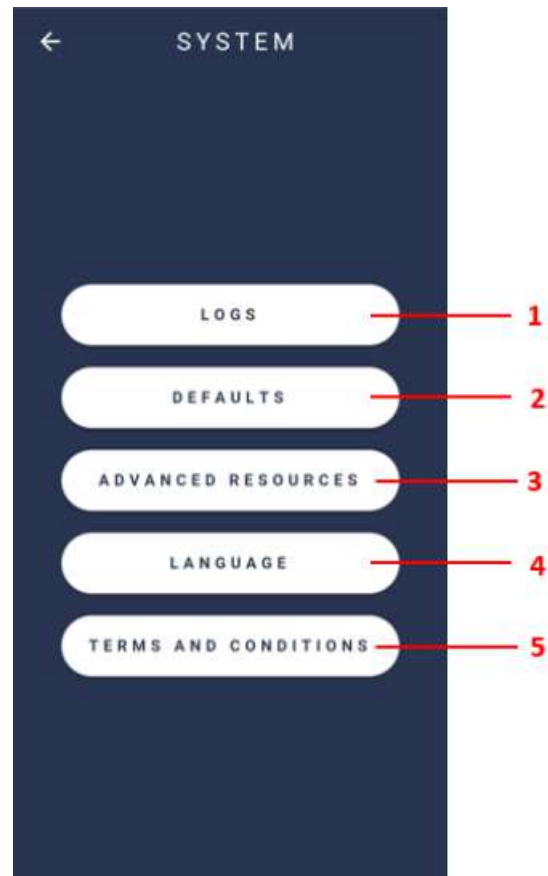


Figure 78: System screen

3.2.4.3.2.1. Logs

Function 1. “Logs”, figure 78, presents options to control the registry, which is used to diagnose system issues, figure 79.

- Log level: Level of internal application event registry
- Native log level: Level of internal application exam registry

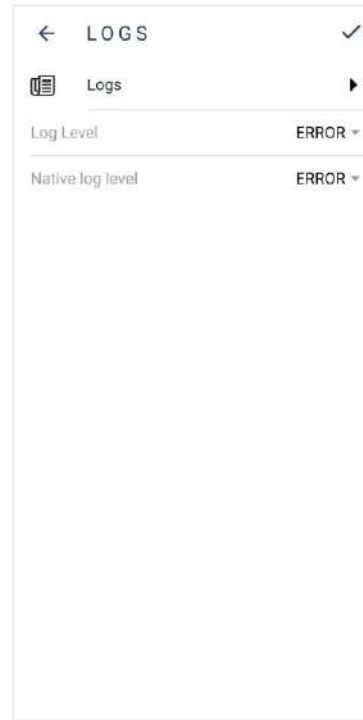


Figure 79: System logs.

3.2.4.3.2.2. Defaults


Access option 2, figure 78, to visualize device default settings. A screen as in figure 80 displays. Click the icon  to change defaults, figure 81.



Figure 80: Device default settings

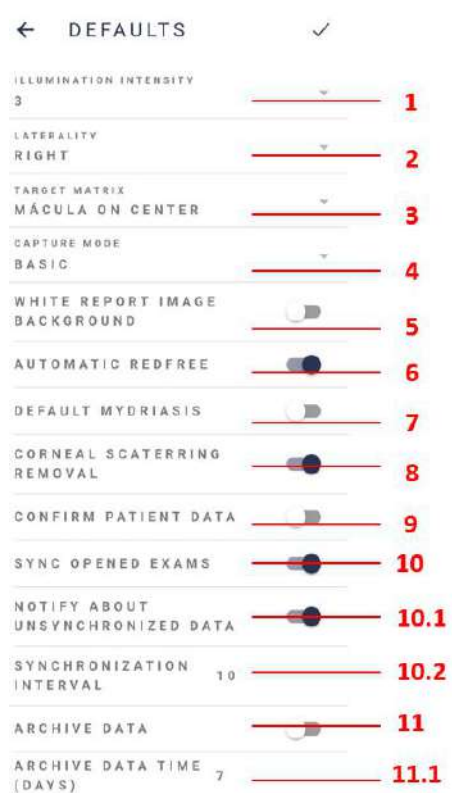


Figure 81: Edit device defaults

1. **Illumination intensity:** Sets image lighting level - default lighting level for image capture screen is 3
2. **Laterality:** Selects default eye exam: right or left
3. **Target matrix:** Sets default fixation target for capture
4. **Capture mode:** Selects basic mode or pro mode
5. **White report image background:** Once enabled, sets the white background for capture
6. **Automatic red free:** When enabled, red-free exams are created automatically
7. **Default mydriasis:** Habilitation recommended for customers that use pupil dilation
8. **Corneal Scattering Removal:** Once enabled, removes corneal scattering
9. **Confirm patient data:** Once enabled, info confirmation is required when patient profile is accessed
10. **Synchronize open-ended exams:** Activated: images synchronize automatically as the captures are made. Inactivated: images only synchronize when the exam is complete
 1. **Notify about unsynchronized data:** System automatic synchronization time in seconds (server sending and/or receiving about patient information, exams, images, and reports).
 2. **Synchronization interval:** Every x seconds the device will execute a synchronization process, communicating with the servers
11. **Archive data:** When activated, patients and exams remain available in device for as long as the set storage time. After that, files are deleted and remain only in cloud storage. It is normally possible to check the patient profile, visualize and edit exams.
 1. **Archive data time (days):** determines, in days, how long the information remains available in the device.

3.2.4.3.2.3. Advanced Resources

Figure 78, option 3, depicts the advanced resources in the **Eyer**[®]: Autoshot, Evaluate Capture Quality, Evaluate heatmap, Generate heatmap image on capture and Instant feedback, figures 82 and 83.



Figure 82: Advanced resources disabled



Figure 83: Advanced resources enabled

3.2.4.3.2.4. Language

Figure 78, option 4, depicts where to set **Eyer®** language: Portuguese (Brazil), English (US) and Spanish, figure 84.



Figure 84: Device language selection

3.2.4.3.2.5. Terms and conditions of use

Terms of Use and Privacy Policy are displayed to the user at his/her first access to the device, for authorization and acceptance, item **3.2.1 Device start screen and access**, figure 16. Select option 5 to access again, figure 78, “Terms and conditions”, and the terms of use display, figure 85. Click “Privacy Policy”, figure 86, to view it.

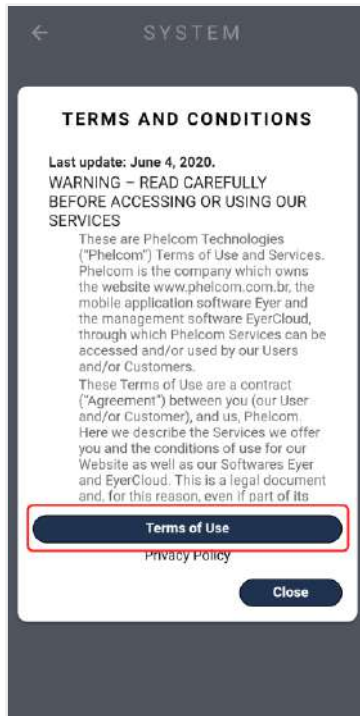


Figure 85: Terms of Use

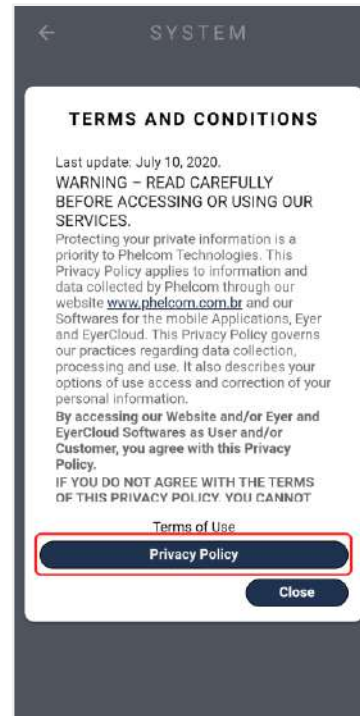


Figure 86: Privacy Policy

3.2.4.3.3. Device

The option “device” contains information on the device, item 3, figure 76. When selected, there are three available options: 1. Calibration, 2. About, 3. User Manual, figure 87.

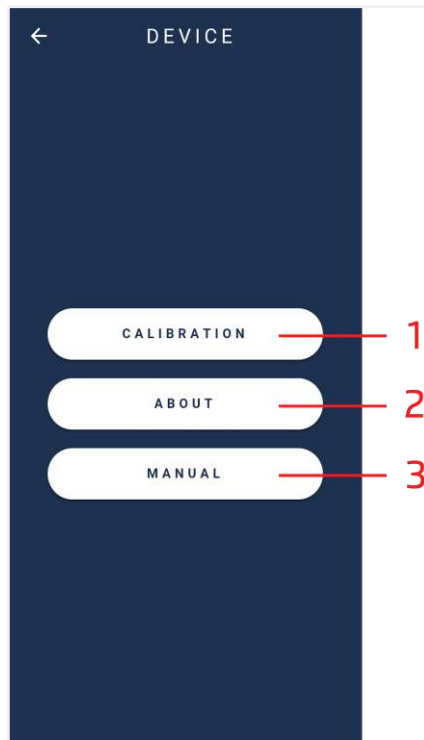



Figure 87: Technical information on the device

3.2.4.3.3.1. Calibration

Click the option 1. “Calibration”, figure 87, to proceed to the screen as in figure 88.

- Direct the device towards a flat and clear surface.
- Activate the “start” button, figure 88, and wait for the device to make technical adjustments.
 Note: In case the camera image is not in a symmetric circle, adjust manually.
 - Select the icons on top of the screen (zoom and targeting).
- Complete the procedure through icon .

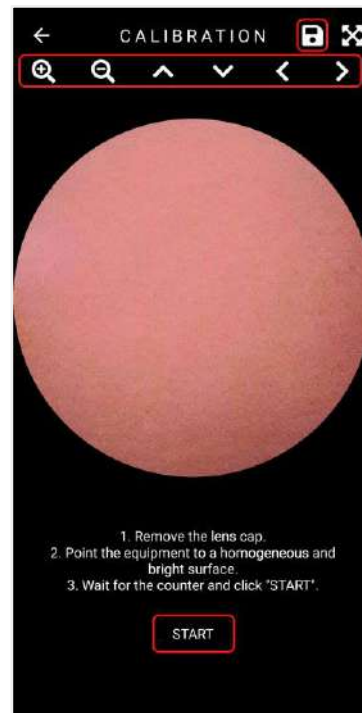


Figure 88: Mobile device calibration screen.

3.2.4.3.3.2. About

Access information on the device through the screen portrayed in figure 87, section 2. User will be directed to the screen in figure 89 which contains:

1. Software version: Information on operation application version
2. Firmware version: Version of the software on device frame
3. Serial number: Individual and non-transferable serial number
4. Device number: Device identification number

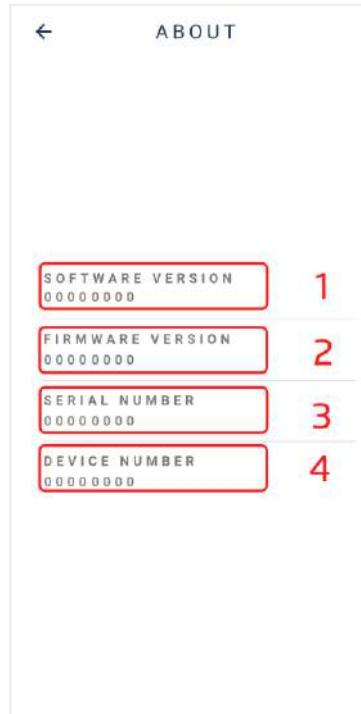



Figure 89: Device information

3.2.4.3.3. User Manual

Access the user manual through the application "Manual", figure 11, section 3 or option 3, "Manual", figure 87.

3.2.4.3.4. Servers

Option 4. "Servers", enables accessing available servers, figure 90.

Select button , figure 90, to add a new server. Select the server type to synchronize, figure 91, and fulfill information as described in item 3.2.1.3.4.1 Common server setup.

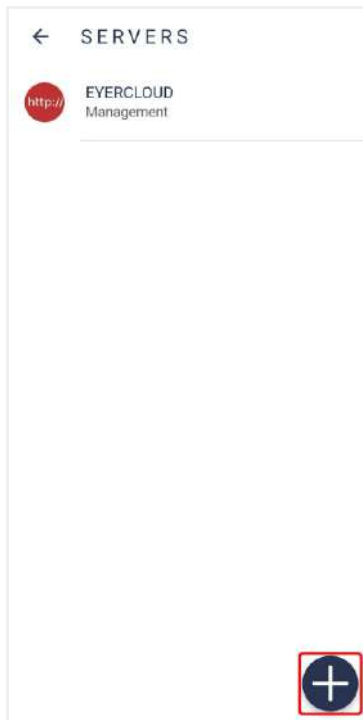


Figure 90: Servers list

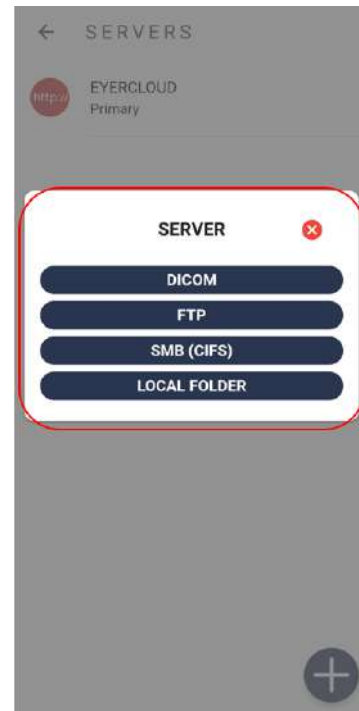


Figure 91: Option to create servers

3.2.4.3.4.1. Common server setup

Any type of server requires defining information, figure 92:

1. **Action:** Defines server action behavior, figure 93:
 - a. **Primary:** Main communication server, all the information will obligatorily be synchronized with this server
 - b. **Mirror:** All the information generated in the device will synchronize with all mirror servers, further than primary server
 - c. **Contingency:** Runs only in case of primary server failure
 - d. **Manual:** Remains available for sending data. It runs only when manually selected
 - e. **Deactivated:** Server is deactivated
 - f. **Management:** Base communication server (EyerCloud). Cannot be removed
2. **Name:** Server ID, which does not need to be unique.
3. **Key:** Generated automatically, based on server name. It must be unique and needs to consist of three characters (from A to Z, capital and/or lowercase) and three numbers (from 0 to 9).

Figure 92: Common server setup

Figure 93: Synchronization action options

3.2.4.3.4.2. DICOM servers setup

Add server information for exam storage (Archive AE) or worklist server information, figure 94, to use DICOM servers.

1. **AE Title:** Application identification in the system
2. **AET:** Server identifier
3. **IP:** Server IP
4. **Port:** Server port
5. **Modality:** Only used in worklist context, represents DICOM file type.

Figure 94: DICOM server setup

3.2.4.3.4.3. FTP server setup

Fill information in as in figure 95 to use FTP servers.

1. Server address
2. Server port
3. Username
4. Password
5. File format to be transferred (DCM or JPG).

The screenshot shows a 'SERVER' configuration screen. At the top, there is a back arrow, the title 'SERVER', and a checkmark. Below this, the 'ACTION' is set to 'MANUAL'. The 'NAME' field is empty. The 'KEY' field is empty. The section is titled 'INPUT FTP SERVER'. It contains several fields: 'SERVER' (with a red line and number 1), 'PORT' (with the value '21' and a red line and number 2), 'INPUT DIRECTORY' (with a red line and number 3), 'USER' (with a red line and number 3), and 'PASSWORD' (with a red line and number 4). Below this is the 'OUTPUT FTP SERVER' section, which has a checkbox for 'SAME AS INPUT' (unchecked). It contains fields for 'SERVER', 'PORT' (with the value '21'), 'OUTPUT DIRECTORY', 'USER', and 'PASSWORD'. At the bottom, there is a 'FILE TRANSFER FORMAT' dropdown menu with 'DICOM' selected and a red line with number 5 pointing to it.

Figure 95: FTP server setup

3.2.4.3.4.4. SMB/CIFS server setup

Fill information in as in figure 96 to use SMB/CIFS servers:

1. Server address
2. Shared folder name
3. Domain
4. When activated, the transfer will use the authentication
5. Username
6. Password
7. File format to be transferred (DCM or JPG).

The screenshot shows a configuration screen for SMB/CIFS servers. At the top, there is a navigation bar with a back arrow, the text 'SERVER', a checkmark, and a 'MANUAL' dropdown menu. Below this, there are several input fields: 'NAME', 'KEY', and a section header 'SMB/CIFS'. Under 'SMB/CIFS', there are fields for 'SERVER', 'SHARE NAME', 'DOMAIN', 'USE AUTHENTICATION' (a toggle switch), 'USER', 'PASSWORD' (with an eye icon for visibility), 'FILE TRANSFER FORMAT', and 'JPG'. Red lines with numbers 1 through 7 point to the following elements: 1. SERVER field, 2. SHARE NAME field, 3. DOMAIN field, 4. USE AUTHENTICATION toggle, 5. USER field, 6. PASSWORD field, and 7. FILE TRANSFER FORMAT field.

Figure 96: SMB/CIFS server setup

3.2.4.3.4.5. Local Folder

Fill information in as in figure 97 to use Local Folder server. Select the folder in figure 98, then click on “Use this folder” in figure 99.

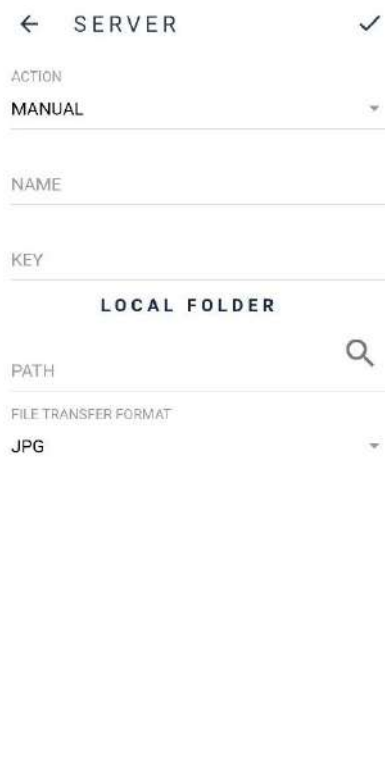


Figure 97 – Local folder setup

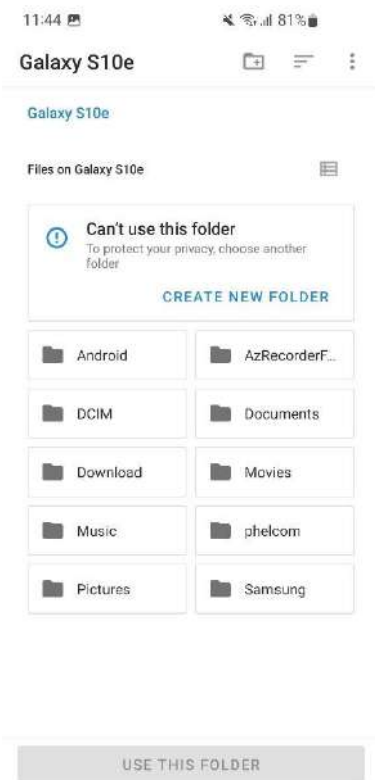


Figure 98 – Local folder setup

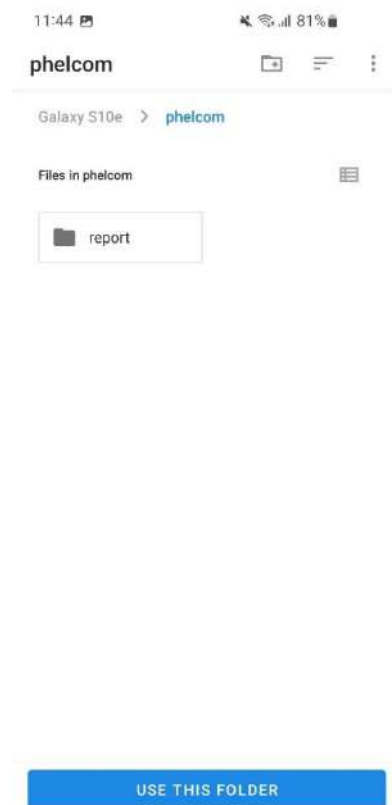


Figure 99 – Local folder setup

3.2.4.3.4.6. DICOM file information

Every Eyer® exam can be converted to DICOM standard, generating a .dcm file. Diverse fields are filled in for that standard, as the TAGS that follow below:

- **PatientID** → Built from the clinic medical record number, with a prefix defined in the field “DICOM Prefix” in **Eyer®** systems screen. *Example:* For a clinic registered with a CNS medical record, a DICOM file with **PatientID** value “phelcom_cnsPaciente” will be generated.
- **PatientComments** → Has a JSON structure with patient anamnesis and diopter information. *Example:*

```

{“anamnesis”: {
  “hypertension”:true,
  “smoker”:true,
  “glaucoma”:true,
  “cataract”:true
},

```


```

"dipter":{
  "right":{
    "spherical": "-3.25",
    "cylindrical": "-0.75",
    "axis": "90"},
  "left":{
    "spherical": "-3.25",
    "cylindrical": "-0.75",
    "axis": "90"},
  ,
  "email": "contato@emailcom.br"
}

```

- **PatientSex** → Always in the format M (*male*), F (*female*) or O (*other*)
- **PatientBirthDate** → Patient Birth Date (YYYYMMDD)
- **PupilDilated** → Dilated Pupil "YES" ou "NO"
- **ImageLaterality** → Exam laterality "R" (*right*) or "L" (*left*)
- **Manufacturer** → Fixed value "Phelcom Technologies"
- **ManufacturerModelName** → Fixed value "Eyer"
- **deviceSerialNumber** → Serial number of the device used in the exam
- **SoftwareVersions** → Version number of the software used in the exam
- **InstitutionName** → Clinic name
- **SeriesDescription** → Type of exam (colored, *redfree*, texture, stereo or panoramic)
- **SeriesDate** → Capture date (YYYYMMDD)
- **SeriesTime** → Capture time (HHmmss)
- **SeriesNumber** → Exam sequential number
- **Modality** → Fixed value "OP" (Ophthalmic Photography)
- **StudyID** → Study Identification (YYYYMMDDHHmmss)

3.2.5. Shutdown procedure

After the operator performs the exams, he must finish the operation by pressing the button  and confirm by Selection "YES".

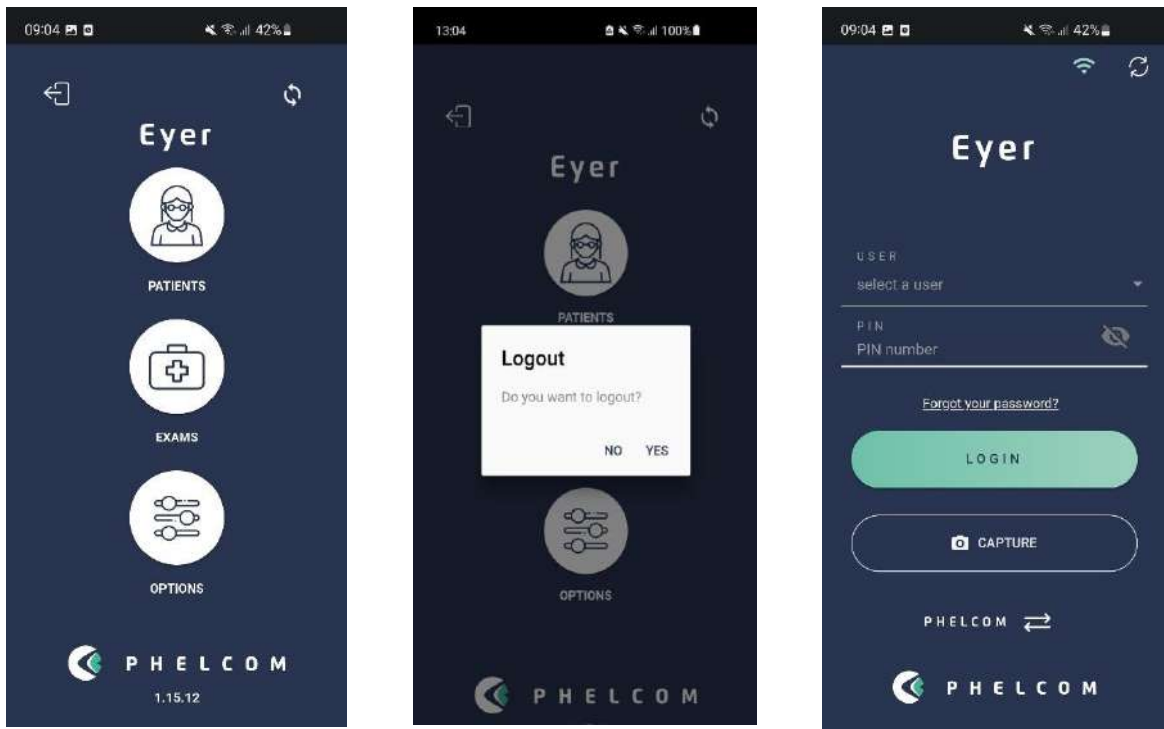


Figure 100 - Finish the operation

The Application will enter the home screen and recommends if for short periods between exams, leave the equipment on standby, quickly pressing the right-side button of the smartphone leaving it on the reset screen.

For long periods without exams, it is recommended to turn off the smartphone by pressing the smartphone’s right side button for a few seconds and confirming the shutdown.

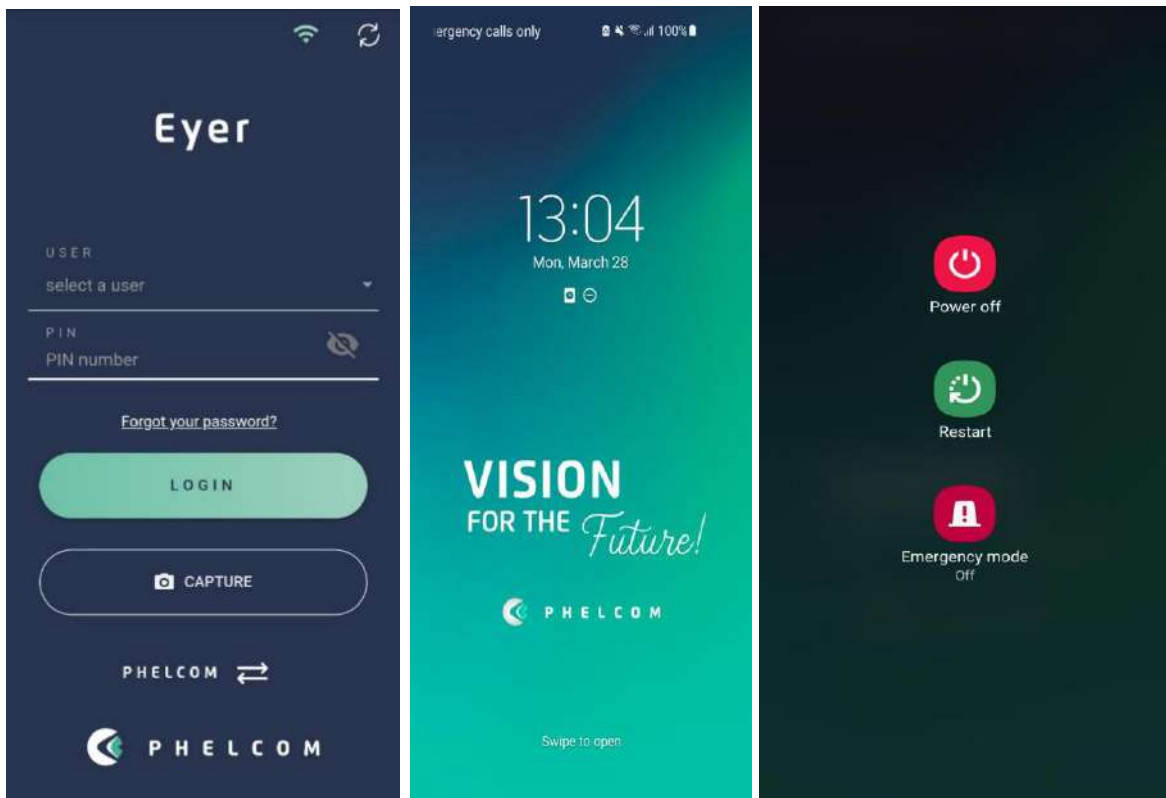


Figure 101 - Turn off the equipment

4. Carrying out exams

4.1. Posterior segment

Provided the knowledge on handling **Eyer**[®] integrated systems, access the image capture screen, figure 43, then follow steps below to capture images.

- Adjust device parameters according to section 3.2.1.1.2.5 Image capture screen
- Stay in front of the patient
- Keep the device perpendicular to the patient
- Hold the optical body with the tips of the left forefinger and thumb. The other fingers rest on the patient's head until the capture is complete
- Hold **Eyer**[®] with the right hand
- Ask the patient to open both eyes wide and cover the eye that will not be examined with a cupped hand
- Ask the patient to look fixedly at the device red light
- Smoothly bring the device closer to the patient's ocular region so that the Eyecap is well coupled, and the image is homogeneous, completely covering the circle, figure 102
- Left hand moves the device. Right hand only captures the image
- If the retina image is black, move the device away and repeat the procedure
- Proceed to image capture



Figure 102: Device positioning for retina image capture

Captured image displays for a few seconds then is immediately stored in gallery, figure 103, enabling capture screen for new photos.



Figure 103: Example of Posterior segment capture



As examination emits a light flash directly into the patient's eye, it may cause some discomfort and slightly blurred and darkened vision for a few seconds. It is recommended to warn the patient about this.



There are no known contraindications to carrying out fundus examination with Eyer. Nevertheless, the operator must evaluate if the skin of the eye area touched by the equipment is intact and clean. It is also necessary to evaluate if patient's possible specific physiological conditions will not worsen with the slight discomfort of the examination, so that it is justifiable before the benefits.

4.2. Anterior segment

Access capture screen, figure 45, then follow steps below to capture the images, figure 104.

- Stay in front of the patient
- Select “anterior” in capture screen, section 3.2.1.1.2.5 Image capture screen, icon 3
- Select the eye to be examined, left or right, icon 1
- Keep the device perpendicular to the patient
- Hold the optical body with the tips of the left forefinger and thumb. The other fingers rest on the patient’s head until the capture is complete
- Hold **Eyer®** with the right hand
- Ask the patient to open both eyes wide and cover the eye that will not be examined with a cupped hand
- Center the iris in the circle displayed in pre-capture
- Complete capture

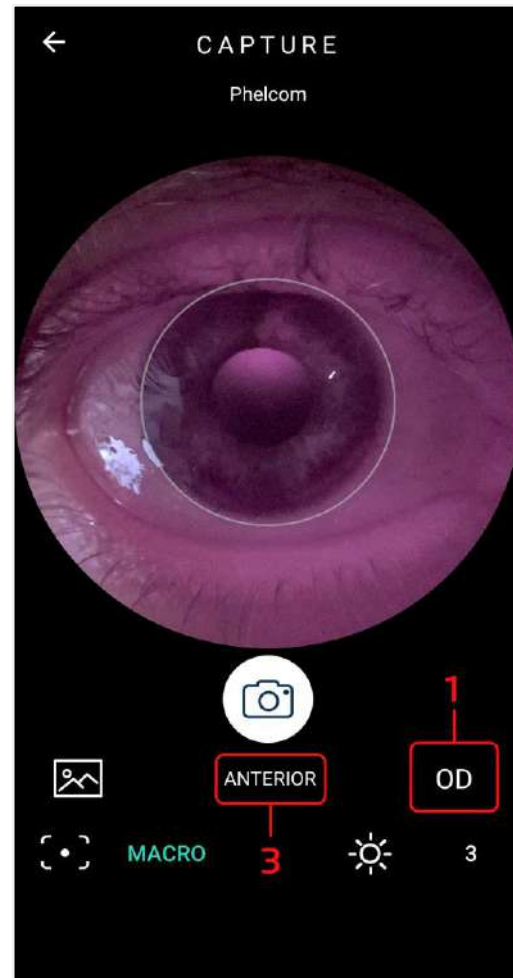


Figure 104: Captured image in anterior segment

5. Maintenance, handling and sanitizing



Read this manual carefully to carry out maintenance and clean Eyer properly. Corrosive chemicals and other abrasives are not advisable.

- Do not clean the device on its accessory base.
- Clean and disinfect the device by wiping it with a piece of cloth moistened in

70° ethyl alcohol, then a dry cloth or wait until the alcohol evaporates. Same procedure fits for the Eyecap.

- Clean lens by slightly removing dust, or other dirt, using a microfiber piece of cloth, either dry or lightly moistened in acetone



Do not clean electrical parts and connectors.

Do not let liquids leak inside orifices, since it may damage the device permanently.

It is not possible for the user or operator to carry out maintenance in this device. Manufacturer recommends regular preventive maintenance inspections made by **Phelcom**. Inspection must be done every year to help detect eventual damage, increase device safety, and lengthen its service life.

There are no interchangeable parts in the device.



Only use Phelcom or authorized technical support.

6. Packing, storage, transportation, site selection, operation, and environmental conditions

Consider the following directions:

- Use the original package or an appropriate case to transport and store the device. Always follow its markings. Avoid keeping it in environments with excessive humidity or thermal variation, even if packed.
- Conform to the safety labels affixed to device package.
- Avoid impacts (shock, falls, etc.) that may cause mechanical, optical and/or electronic damage, resulting in loss of calibration made by **Phelcom**.
- Location for storage, transport and operation must have controlled environmental conditions. Temperature must be from 5°C (41°F) to 40°C (104°F). Maximum relative humidity is 75%, Atmospheric Pressure must be from 800hPa to 1060 hPa.
- Do not expose device to direct sunlight for more than 5 minutes.
- Always keep the device and its surrounding area clean.

7. Accompanying parts and accessories

Following parts and accessories compose the device, figure 105:



Figure 105: Equipment parts and accessories

7.1. Accessories

1. Eye Retinal Camera
2. Dock station (Charging station)
3. Eyecap
4. Lens Protector
5. Storage case
6. Cleaning cloth
7. Allen wrench
8. Quick Start Guide
9. Welcome card
10. Shipping box
11. Power Supply
12. Slit-lamp adapter
13. Sílica gel Bags

8. Disposal

After routine cleaning, as described in section 5. Maintenance, handling, and sanitizing, the device presents no additional risk for being a medical device. For disposal purposes, it can be considered a simple electric device.

Disposal of the device or its parts must follow environmental regulations, directive 2002/96/CE, through recycling companies or licensed solid waste disposal in the country of operation.

Disposal of device or parts does not need to be sent to the factory. Consult **Phelcom** local authorized supplier before disposal. Users are responsible for disposal of **Eyer**[®] and used parts after service life and must respect local current law. Do not dispose of the product or parts with common household waste.

Constantly check all device components for risks to the environment, team and public. Also check about safe disposal, according to local protocols.

While out of operation, **Eyer**[®] must be protected from inadvertent non-qualified use.

Package is recyclable, consisting of approximately 250g of cardboard and 50g of plastic, figure 106 and figure 107.



Figure 106: Disposal of device and parts.



Figure 107: Disposal of packaging.

9. Cables and connections

9.1. Cables

This device does not have cables since it utilizes the smartphone battery. Use the smartphone's original cable to charge.

9.2. Connections

There are two possible charge connections:

- **Smartphone charge:** Plug a charger connected to the power grid, figure 108, in the **Eyer®** USB-C port, figure 109.
- **Accessory base charge:** Install the power cable at the bottom of the accessory base, figure 110, and plug **Eyer®** to charge, figure 111.

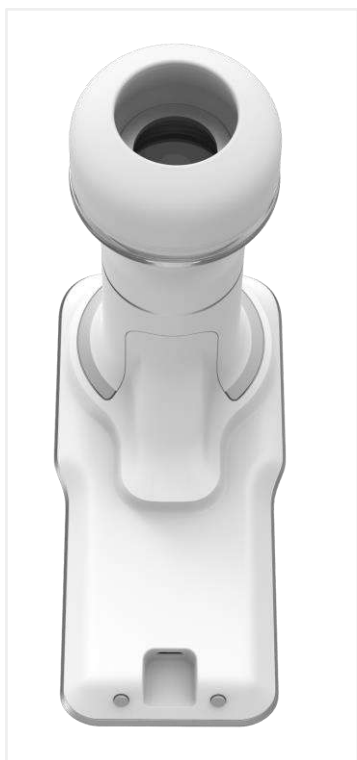


Figure 108: **Eyer®** connected to charger

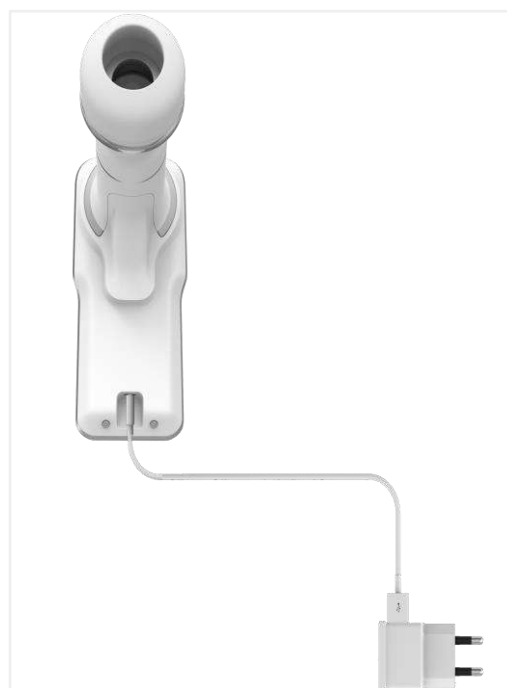


Figure 109: **Eyer®** back view



Figure 110: Cable connected at the bottom of the accessory base



Figure 111: **Eyer**® positioned for accessory base charge

Power grid isolation is possible through the smartphone charger while the battery charges. Always use the original charger in good conditions.



Avoid touching the patient or exposed electrical contacts during procedures that expose them, as changing the accessory for charging or eventual smartphone replacement.

Use of accessories, transducers and cables which are not specified in this manual may rise electromagnetic emission and reduce electromagnetic immunity.

10. Technical Data

10.1. Optical characteristics

Phelcom **Eyer**[®] complies with all requirements of ANSI Z80.36-2016, ISO 10940:2009, ISO 15004-1 and ISO 15004-2 and is classified as a Group 1 fundus camera. It means that the patient is not exposed to any risks related to light of the device during retinal imaging. Optical characteristics of Phelcom **Eyer**[®] are summarized in table 2.

Table 2 - **Optical characteristics of Phelcom Eyer**[®]

Non-mydratric operation	Eyer [®] uses near infrared illumination centered at 850 nm in the preview mode that allows retinal imaging without the use of eye drops for pupil dilation. The minimum pupil diameter to carry out retinal exams is 3 mm
Instantaneous Field Of View (FOV)	45°
Patient diopter compensation range	- 20 D to +20 D with auto focus or manually
Internal fixation dots	9 dots to help the registration of macula and optic disc nerve centered and peripheral retinal images
Exams	Color retinography, red-free retinography and anterior segment imaging
Resolution	Camera resolution 12 MP Image resolution 1600 x 1600 px

Chart 1 shows a graphic about **Eyer**[®] emission spectrum for retinal and anterior segment imaging and Chart 2 shows a graphic about **Eyer**[®] emission spectrum in the preview mode.

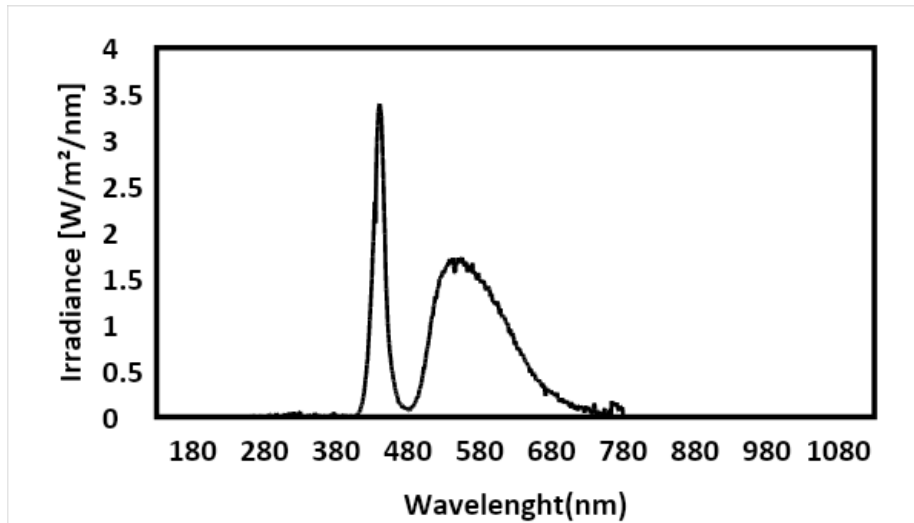


Chart 1: Eyer® emission spectrum for retinal and anterior segment imaging

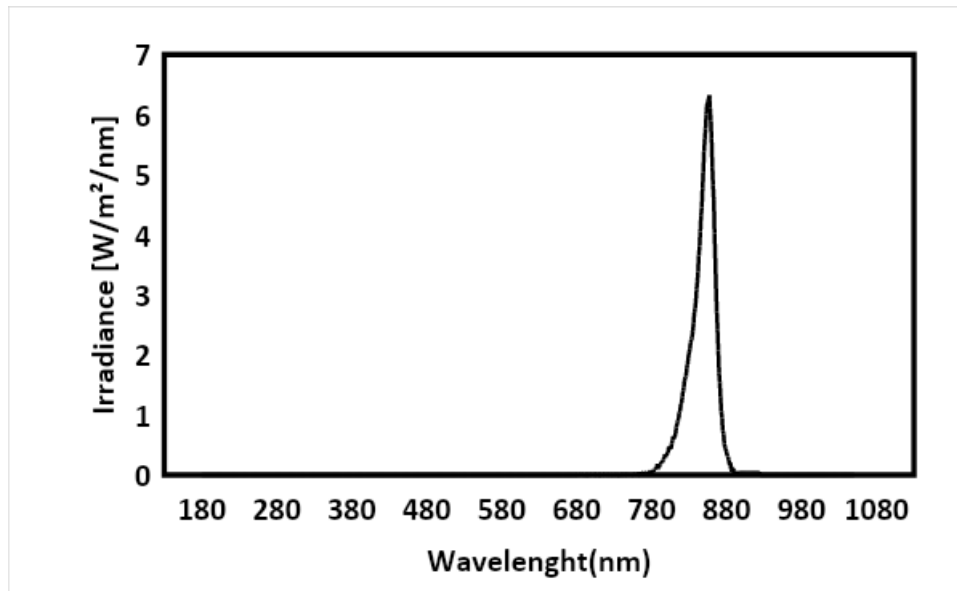


Chart 2: Eyer® emission spectrum in the preview mode

10.2. Electrical characteristics

Patient exposure to any energy related risk coming from the power grid is prevented by a software lock that unable exam procedures while charging. Table 3 presents information on the device and its classifications.

Table 3 - Eyer® mobile device specifications

Protection against electrical shock	Class 2 equipment
Degree of protection against electrical shock	BF type equipment
Degree of protection against harmful water penetration	Console: Unprotected (IPX0)
Sterilization or Disinfection methods	Sterilization: not applicable Disinfection: use a clean cloth moistened in water and mild detergent
Degree of safety of application in the presence of flammable anesthetic mixture	Not suitable for use in the presence of flammable anesthetic mixture with air, oxygen, or nitrous oxide.
Mode of operation	Device for continuous operation with intermittent charge
Supply Voltage	5Vcc (supplied by smartphone)
Power	Power in standby: 0,15W Power in operation: 2W
Maximum current	500 mA
Frequency	0Hz (continuous current)
Dimensions (height x width x length)	185mmX85mmX160mm
Weight	600g
Family/Model	Eyer Retinal Camera / NM-STD
Software/App	Eyer®

11.Warning



Phelcom is not responsible for the device in case it is disassembled and/or modified by unauthorized people. No modification is allowed for this device.

If the device is used in another way than specified in this User Manual, its warranty will automatically void. Carefully read the terms of use. Contact our Technical Support in case of doubts.


Contact Technical Support in case of an accident or any abnormal behavior. Always follow authorized medical protocols and current laws.

Device use does not damage the environment; however, its disposal must follow the provisions in section 8. Disposal.

You have acquired a high technology device made by a Brazilian company. That means you can access us after sales service through the contacts in the last page of this Guide.

12.Troubleshoot Guide

This chapter presents some operational issues the device may present in use. User can check for technical specifications in table 4 that will serve to correct simpler issues or to facilitate contact with **Phelcom** technical support.



If the issue listed persists even after trying to solve it as described, technical support service is recommended.

Table 4 - **Technical specifications for operational issues**

ISSUE	POSSIBLE SOLUTION
Equipment does not turn on	<p>Check if the smartphone is on.</p> <p>Check if there is enough battery charge in the smartphone.</p> <p>Check if the smartphone is connected to the equipment.</p>
Equipment operation halts	<p>If the equipment randomly turns off during operation, check, at first, if there is connection between the smartphone and the equipment body.</p>
Smartphone do not perfectly fit the equipment.	<p>Make sure the smartphone is the same sent by Phelcom.</p>
Smartphone do not charge on the accessory base.	<p>Check if the accessory base is connected to the smartphone charger.</p> <p>Ensure the use of the adapter for charging.</p> <p>Check the connection of the</p>

	smartphone to the accessory base.
Low quality of examination images	<p>Make sure the smartphone is the same sent by Phelcom.</p> <p>Make sure the eye lighting is correctly used and attached to the examined patient's eye.</p> <p>Read this User Manual carefully and follow suggested instructions and recommendations.</p>
Application does not work	<p>Check if the correct Eyer App, in its updated version, is selected.</p> <p>Reinstall the Eyer App.</p>
User forgot the password	<p>Click on "forgot password" to generate a new password. An email message will be sent to change the password, then the access will be granted.</p>

13. Electromagnetic Safety Standards

This device has been tested and found to comply with the limits for medical devices to the IEC 60601-1-2:2014. Special precautionary measures apply to this device regarding electromagnetic compatibility (EMC). To avoid electromagnetic disturbances, the device may only operate and serviced in accordance with the user manual using the components supplied by Phelcom.

If the performance of Eyer Retinal Camera is lost or degraded due to electromagnetic disturbances, it may cause unexpected or adverse operation of this device. If a malfunction cannot be rectified, please contact your location distributor or Phelcom customer service.

Customers or users of this device must assure **Eyer**[®] is used in environmental accordance with the specification of this guide, following the descriptions for its adequacy to emission and electromagnetic immunity regulations.



Use of this equipment adjacent or stacked with other equipment should be avoided because it could result in improper operation. If such use, if necessary, this equipment and the other equipment should be observed to verify that they are operating normally.

The device should not be operated in the vicinity or with high-frequency surgical equipment.



Use of accessories, transducers, and cables other than those specified or provided by the manufacturer of this equipment could result in increased electromagnetic emissions or decreased electromagnetic immunity of this equipment and result in improper operation.



Portable RF communications equipment (including peripherals such as antenna cables and external antennas) should be used no closer than 30 cm (12 inches) to any part of the Eyer Retinal Camera including cables specified by the manufacturer. Otherwise, degradation of the performance of this equipment could result.

Replacement cables may only be purchased at Phelcom. the use of Accessories, any converters or cables which are not specified in this user manual or have not been purchased as spare parts from Phelcom can result in increased emissions or reduced immunity of the device.

13.1. Supplier declaration and guidelines - Electromagnetic emissions

Table 5 presents information on the electromagnetic environment destined for **Eyer®** use.

Table 5 - **Information on compliance with electromagnetic immunity requirements based on Table 1 – IEC 60601-1-2, 2014**

IMMUNITY TEST	COMPLIANCE	ELECTROMAGNETIC ENVIRONMENT - DIRECTIVE
IEC CISPR 11 RF emissions	Group 1	Eyer uses RF energy only for its internal function. Therefore, its RF emissions are very low and are not likely to cause any interference in nearby electronic equipment.
RF emissions	Class A	Eyer is suitable for use in all establishments, including domestic establishments and those directly connected to the public low-voltage power supply network that supplies buildings used for domestic purposes.
Harmonic IEC 61000-3-2 emissions	Compliant	
Emissions due to voltage fluctuation / flickering. IEC 61000-3-3	Compliant	

13.2. Supplier declaration and guidelines - Electromagnetic immunity

Eyer® maintains basic safety and performance when used in the electromagnetic environment specifies tables 6 and table 7. The customer or the user of the device should ensure that it is used in such an environment.

Table 6 - Information on compliance and electromagnetic immunity requisites for devices that do not aim LIFE-SUPPORT, based on Table 2 - IEC 60601-1-2, 2014


IMMUNITY TEST	IEC 60601 TEST LEVEL	COMPLIANCE LEVEL	ELECTROMAGNETIC ENVIRONMENT - GUIDANCE
Electrostatic Discharge (ESD) IEC 61000-4-2	± 8 kV by contact ± 2, 4, 8 and 15 kV by air	Compliant	Floors should be wood, concrete, or ceramic tile. If floors are covered with synthetic material, the relative humidity should be at least 30%.
Fast electrical transient / Burst train IEC 61000-4-4	±2Kv, 100kHz	Compliant	Mains power quality should be that of a typical commercial or hospital environment.
Surges IEC 61000-4-5	± 0,5 and 1 kV	Compliant	Mains power quality should be that of a typical commercial or hospital environment.
Voltage drops, short interruptions and voltage variations in supply input lines IEC 61000-4-11	100 % 0,5 cycle 100 % 1 cycle 30% 30 cycles 100% 300 cycles	Compliant	Mains power quality should be that of a typical commercial or hospital environment. If the user of the Eyer requires continued operation during power mains interruptions, it is recommended that the device be powered from an uninterruptible power supply or

			battery.
Electromagnetic field in power frequency (50/60 Hz) IEC 61000-4-8	30 A/m	Compliant	Power frequency magnetic fields should be at levels characteristic of a typical location in a typical commercial or hospital environment.

NOTE: Ut is the AC supply voltage before applying the test level

Table 7 - Recommendations for separation distances between device and RF emission sources based on Table 4 – IEC 60601-1-2, 2014

IMMUNITY TEST	IEC 60601 TEST LEVEL	COMPLIANCE LEVEL	ELECTROMAGNETIC ENVIRONMENT - DIRECTIVE
Conducted RF IEC 61000-4-6	3 Vrms 150 KHz to 80 MHz & 6 Vrms ISM frequency	3 Vrms 150 KHz to 80 MHz & 6 Vrms ISM frequency	Portable and mobile RF communication equipment must not be used near any Eyer part, including cables, within a shorter separation distance than recommended, which is calculated from the equation applicable to the transmitter frequency. Recommended separation distance: $d = 1,2 \sqrt{P}$ (80 MHz to 800MHz) $d = 2,3 \sqrt{P}$ (800 MHz to 2.7 GHz) Where P is the transmitter maximum rated output power, in Watts, according to the transmitter manufacturer, and D is the recommended separation distance in meters (m). Field intensity established by an
Radiated RF IEC 61000-4-3	3 V/m 880 MHz to 2.7 GHz	3 V/m	

			<p>RF transmitter is recommended, as determined through local electromagnetic inspection, ^ato be lower than the compliance level in each frequency range. ^b Interference may occur around the equipment marked with the</p> <p style="text-align: right;">  </p> <p>following symbol:</p>
--	--	--	--

NOTE 1 – At 80 MHz and 800 MHz, the higher frequency range applies.

NOTE 2 – These guidelines may not apply to all situations. Electromagnetic propagation is affected by absorption and reflection of structures, objects and people.

NOTE 3 - The ISM (industrial, scientific, and medical) bands between 0.15Mhz to 80 Mhz are 6.765-6.795 MHz; 13.553-13.567 MHz; 26.957-27.283 MHz and 40.66-40.70 MHz.

A) Field intensities established by fixed transmitters, such as base radio stations, telephones (cellphones, wireless phones) and land mobile radios, amateur radio, AM and FM radio transmission, and TV transmitters cannot be predicted theoretically with precision. A local electromagnetic inspection is recommended to evaluate the electromagnetic environment due to fixed RF transmitters. If the measurement of field strength where **Eyer®** is used exceeds the compliance level above, **Eyer®** must be observed to verify operation normality. Additional procedures may be necessary if abnormal performance is observed, such as reorienting or relocating **Eyer®**.

B) Field strength should be less than 3V/m for a frequency range above 150 KHz to 80 MHz.

13.3. Recommended minimum separation distances from mobile RF communication devices to Eyer®

Eyer® maintains basic safety and essential performance when used in an electromagnetic environment in which radiated RF disturbances are controlled. The customer or the user of Eyer Retinal Camera can help prevent electromagnetic interference by maintaining a minimum distance between portable and mobile RF communications equipment (transmitters) and Eyer Retinal Camera as recommended

in table 8, according to the maximum output power of the communications equipment.

Table 8 - Recommendations for separation distance between portable and mobile device from RF emission sources, based on Table 6 - IEC 60601-1-2, 2014

Transmitter maximum output voltage (W)	SEPARATION DISTANCE ACCORDING TO TRANSMITTER FREQUENCY (m)		
	150 kHz to 80 MHz $d = 1,2\sqrt{P}$	80 MHz to 800 MHz $d = 1,2\sqrt{P}$	800 MHz to 2,5 GHz $d = 2,3\sqrt{P}$
0,01	0,12	0,12	0,23
0,1	0,38	0,38	0,73
1	1,2	1,2	2,3
10	3,8	3,8	7,3
100	12	12	23

For the transmitter rated at maximum output power not listed above, the recommended separation distance d in meters () can be estimated using the equation applicable to the frequency of the transmitter, where P is the maximum output power rating of the transmitter in watts (W) according to the transmitter manufacturer.

NOTE 1 - At 80 MHz to 800 MHz, the separation distance for the highest frequency range applies.

NOTE 2 - These guidelines may not be applied to all situations. Electromagnetic propagation is affected by the absorption and reflection of structures, objects, and people.

NOTE 3 - Portable and mobile RF communication equipment may affect Eyer®.

13.4. Radio frequency interference

Eyer® follows the regulation IEC 60601-1-2:2014, following all applicable requirements regarding electromagnetic compatibility, provided that local environmental limitations are met.



The device cannot be used in environments with atypically high electromagnetic fields such as an MRI room or close to CT, diathermy, RFID, and electromagnetic security systems such as metal detectors. In the case that there exist RF emitters (e.g., RFID), which might not be visible, the device can potentially be exposed to fields from these RF emitters without the user's awareness causing equipment malfunction.

14. Biocompatibility

Phelcom declares that the material used in the applied part of the device **Eyer®** is certified by ISO 10993-1 - Biological evaluation of healthcare products, thus offering no risk regarding its use.

The Eyecap accessory is manufactured by Phelcom Technologies and has a use by date of 5 years.

For more information, please contact:

Phelcom Technologies

Registration / FEI Number: 3017175640

Owner/Operator Number: 10072211











DUNS number: 945005233

820, José Missali St. Santa Felícia District
São Carlos - SP - Brazil - ZIP Code: 13.562-405
Phone.: +55 (16) 3413-3088
support@phelcom.com

15. Glossary and symbols

This section presents all the symbols related to device safety and their meanings, table 9, as well as the labels on its protective package.

Table 9: **Labels, markings, and symbols**

MARKING	SYMBOL	MARKING	SYMBOL
	Fragile; handle with care		Operator's manual
	Keep away from rain		Class II equipment
	Manufacturer		Direct current
	Keep away from sunlight		Earth; Ground
	Temperature Limit		Material recycling

	<p>Type BF Applied Part</p>		<p>Waste electrical and electronic disposal</p>
	<p>General warning sign</p>		<p>Federal law restricts this device to sale by or on the order of a physician or licensed practitioner</p>

16. Cybersecurity Information

16.1. Objective

The purpose of this section is to summarize the cybersecurity controls of the **Eyer**[®] Retinal Camera system.

16.2. System overview

The **Eyer**[®] Retinal Camera system has the following interface that are critical for cybersecurity:

- Eyer administration may manage proper user management credentials and permissions
- Sensitive data can be shared outside of application context, which leads to non-encrypted data
- If the device is disassembled, its USB ports can be accessible

16.3. General principles

Cybersecurity risk management is a shared responsibility among stakeholders including the medical device manufacturer, the user, and the healthcare facility. Failure to maintain cybersecurity can result in compromised device functionality, loss of data availability or integrity, or expose other connected devices or networks to security threats.

The smartphone is limited to install Android operating system and is dedicated for **Eyer**[®] Retinal Camera, for the risk of viruses and other malwares, users must install and enable anti-virus software and follow the suggestion of third-party software (including virus updates) to update it.

For any vulnerability or bugs found, the user should report via email to: privacy@phelcom.com.

16.4. Cybersecurity functions

16.4.1. Authentication of users

Eyer[®] Retinal Camera system uses Android as the main operating system. The operating system itself allows the end user to establish and configure "User Accounts" for the equipment with various authentication forms, such as numeric, patterns and facial and fingerprint recognition.

Phelcom's **Eyer**[®] application has an authentication method to access its main functions and it is mandatory for administrators to configure it all in a secure and safe way.

16.4.2. Auto-logout

- The operating system can prevent access and misuse by authorized users if the device is left idle for a period.
- The length of inactivity time before auto-logout screen lock is user/administrator configurable.
- The auto-logout/screen lock should avoid unauthorized access to the **Eyer®** application to preserve system and data confidentiality, integrity, and availability.

16.5. Data backup

- To avoid the loss of patient data due to damage to the storage device of the equipment, it is recommended that the user should regularly back up data.
- It is recommended to store the data in multiple different and independent storage media to disperse the risk of data loss or damage to the storage device.

17. Term of Warranty

Warranty period is 12 (twelve) months, counting from the invoice issuance date.

Warranty coverage is restricted to manufacturing defects of the systems and components in this device, properly proven by an accredited **Phelcom** representative.

In cases of technical support and maintenance, all transport, storage, and shipping costs are borne by the buyer. During the device warranty period, shipment(s) must be in the original packaging, under penalty of warranty void.

This warranty is automatically canceled in case the device has been used in any different way than the recommended in this User Manual. Warranty is also canceled in case of accidental fall, opening or disassembly of the frame.

Phelcom is not responsible for personal injuries, lesions or wounds resulting from device misuse.

Phelcom legal liability refers to this device and its use is limited to the purchase value paid by the Customer.

In case the commercial relation to **Phelcom** is not a purchase and sale agreement, the applicable warranty and responsibility terms shall mandatorily be defined in specific agreement.



Ophthalmic fundus camera - GMDN: 10551

MANUFACTURE AND DISTRIBUTION

Phelcom Technologies

Registration / FEI Number: 3017175640

Owner/Operator Number: 10072211

DUNS number: 945005233

820, José Missali St. Santa Felícia District
São Carlos - SP - Brazil - ZIP Code: 13.562-405
Phone: +55 (16) 3413-3088
support@phelcom.com

US Agent:

Passarini Regulatory Affairs of America LLC
201, South Biscayne Boulevard
Suite 1200 - Miami Center Building
Miami, FL US 33131



Phone: 886 2641043 Ext

Fax: 866 2641043

Email: usagent@rapassarini.com.br

PHELCOM EYER® - NM-STD USER MANUAL - REVIEW 8



12/15/2022



P H E L C O M